



ガスプリング用プレート 一底溝固定タイプ
氮气弹簧用板
 一底槽固定型一

ガスプリング

氮气弹簧

RoHS 10

FFC
FFCB
FFCA

FFC32-38 FFC45~195 FFCB FFCA

M 材质 相当于S45C
 S 表面处理 四氧化三铁保护膜(Fe₃O₄)

A	a	C	d	f	h	j	g	e	Catalog No.	适用氮气弹簧						建议螺栓 4个	
										GSV	GST	GSH	GSK	GSSC	GSU		
50	35	49.5	6.6	21	17	6.5	7	4	FFC	32	350	350	-	150	750	300	CB6-18
55	40	56.7	6.6	21	17	6.5	7	4		38	500	500	-	250	1000	-	CB6-18
70	50	70.7	9	20	-	-	7	4		45	750	750	-	500	-	-	CB8-20
75	56.5	79.9	9	24	-	-	12	8		50	1000	-	1000	750	1800	-	CB8-25
85	63.5	89.8	11	24	-	-	12	8		63	1500	-	1500	-	3000	-	CB10-30
100	73.5	104	11	24	-	-	12	8		75	2400	-	2400	1500	4700	-	CB10-30
120	92	130.1	13.5	24	-	-	12	8		95	4200	-	4200	3000	7500	-	CB12-30
140	109.5	154.9	13.5	24	-	-	12	8		120	6600	-	6600	5000	12000	-	CB12-30
190	138	195.1	17.5	24	-	-	12	8		150	9500	-	-	7500	18500	-	CB16-40
210	170	240.4	17.5	24	-	-	13	8		195	20000	-	-	10000	-	-	CB16-40

FFC符合ISO 11901-2标准。(※FFC63除外)

A	a	C	d	f	g	e	Catalog No.	适用氮气弹簧						建议螺栓 4个	
								GSV	GST	GSH	GSK	GSSC	GSU		
100	73.5	103.9	11	24	12	8	FFCB	63	1500	-	1500	-	3000	-	CB10-30

FFCB符合VDI 3003标准。

A	a	B	b	d	f	g	e	Catalog No.	适用氮气弹簧						建议螺栓 4个	
									GSV	GST	GSH	GSK	GSSC	GSU		
50	40	27	18	6.6	20	7	4	FFCA	32	350	350	-	150	750	300	CB6-18
55	44	33	20	6.6	20	7	4		38	500	500	-	250	1000	-	CB6-18
70	57	40	27	9	25	7	4		45	750	750	-	500	-	-	CB8-20
75	62	45	32	9	25	12	8		50	1000	-	1000	750	1800	-	CB8-25
85	69	58	42	11	30	12	8		63	1500	-	1500	-	3000	-	CB10-30
100	84	70	54	11	30	12	8		75	2400	-	2400	1500	4700	-	CB10-30
120	100	90	70	13.5	40	12	8		95	4200	-	4200	3000	7500	-	CB12-30
140	120	115	95	13.5	50	12	8		120	6600	-	6600	5000	12000	-	CB12-30
190	165	145	120	17.5	60	12	8		150	9500	-	-	7500	18500	-	CB16-40
210	185	190	105	17.5	80	13	8		195	20000	-	-	10000	-	-	CB16-40



Order
订货范例

Catalog No.

FFC38
FFCA75
FFCB63
FCM19
FFS63



Delivery
交货期

请通过 **MISUMI** 询价。
(<https://www.misumi.com.cn>)

RoHS 10

FCM

M 材质 相当于S45C
 S 表面处理 四氧化三铁保护膜(Fe₃O₄)

RoHS 10

FFS

M 材质 相当于S45C
 S 表面处理 四氧化三铁保护膜(Fe₃O₄)

A	a	B	d	t	Catalog No.	适用氮气弹簧GSV	建议螺栓 2个
45	32	25	7	9.2	FCM	170	CB6-20
50	38	30	7	9.2		320	CB6-20

A	a	C	d	h	g	k	f	Catalog No.	适用氮气弹簧 GST	建议螺栓 4个	
75	53.9	50.5	17	11	25	11	30	FFS	1000 1200	CB10-30	
100	73.5	63.5	17	11	25	11	30		50	1500	CB10-30
100	76.2	75.5	20	13	25	13	30		63	2400	CB12-25
125	98.3	95.5	20	13	25	13	30		75	4200	CB12-25
140	114.3	120.5	20	13	25	13	30		95	6600	CB12-25
175	139.7	150.5	25	17	25	17	30		120	9500	CB16-30

■ 特长

● FFS既可安装在上模上，又可安装在下模上。



Example
使用范例

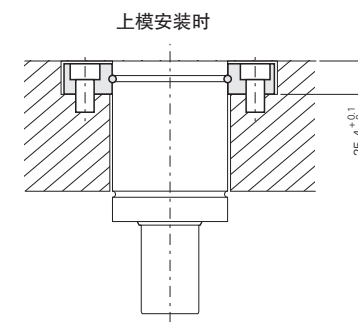
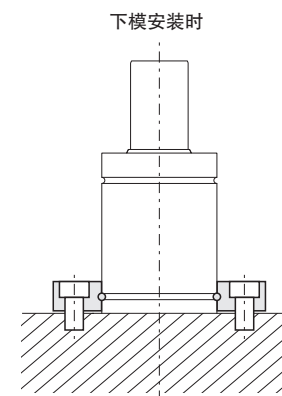

● 负载由氮气弹簧底面承受，与板之间请留出0.4mm的间隙。