

MEFNS200 (θ=00-45)

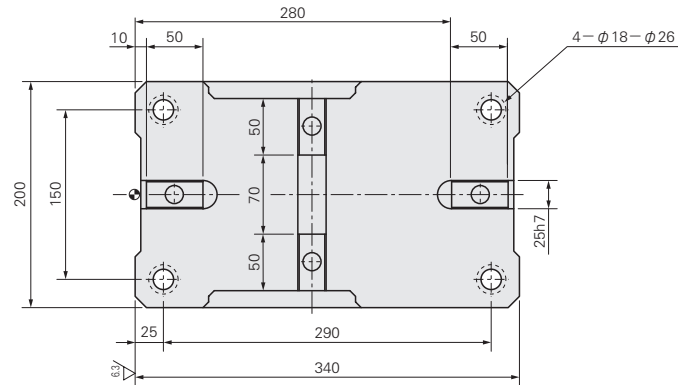

■后方拔出空间

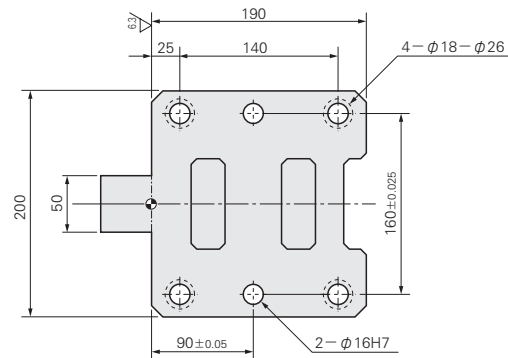
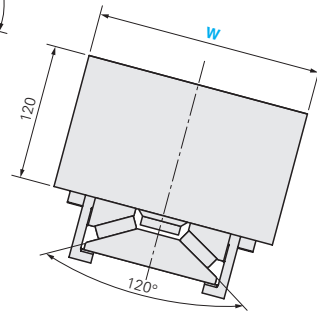
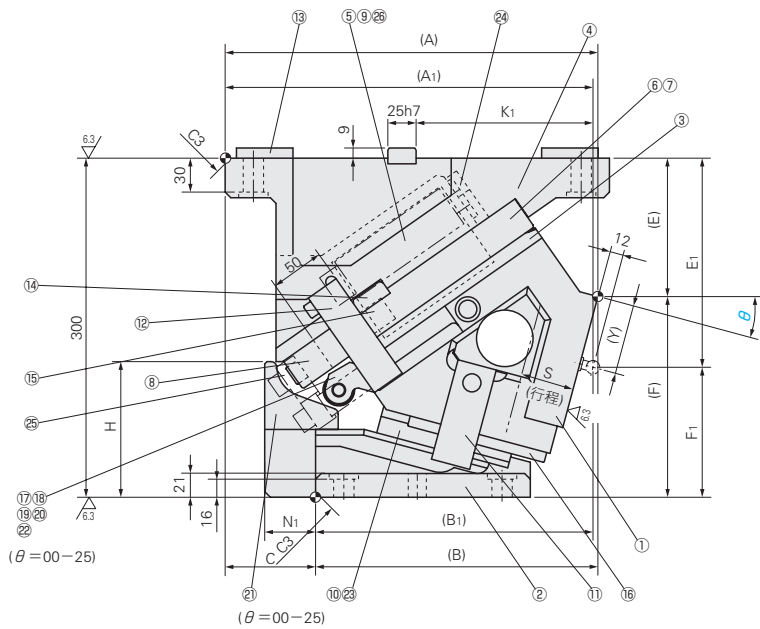
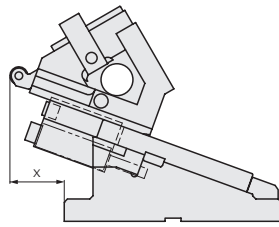

■斜楔行程关系图 P.1343
■构成零件表 P.1347

W	θ	A	A ₁	B	B ₁	C	E	E ₁	F	F ₁	H	K ₁	N ₁	Y	x	
200	00	335.84	347.84	207.84	219.84	128	96.98	170	203.02	130	80	180.5	55	73.02	21	
	05	335.25	340.82	222.25	227.82	113	100.91	175	199.09	125	98	173		73.32	37	
	10	337.27	337.3	236.27	236.3	101	111.09	180	188.91	120	109	165.5		50	67.86	48
	15	329.78	325.45	249.78	245.45	80	122.46	185	177.54	115	120	156.5		45	61.53	66
	20	332.68	323.61	262.68	253.61	70	129.99	190	170.01	110	137	149		42	59.49	71
	25	332.88	319.83	274.88	261.83	58	138.62	195	161.38	105	154	140	37	56.61	83	
	30	334.28	315.39	286.28	267.39	48	148.28	205	151.72	95	125	132.5	30	58.57	90	
	35	329.8	305.16	296.8	272.16	33	158.89	215	141.11	85	135	125	25	60.1	100	
	40	321.35	291.18	306.35	276.18	15	170.38	225	129.62	75	155	117.5		61.23	111	
	45	314.86	279.49	314.86	279.49	0	182.66	235	117.34	65	111.5	62.03		116		

行程 S	加工力KN (tonf)	总重量 kg	Catalog No.	W	θ	弹簧型号
32.1	353.0 (36.0)	90.3	MEFNS	200	00	GK ISO NGK NISO
35.5		88.0			05	
38.9		87.5			10	
42.4		87.0			15	
46.1		85.8			20	
50.0		86.2			25	
54.3		85.6			30	
59.0		86.2			35	
64.3		86.6			40	
70.4		88.0			45	

■弹簧类型

弹簧型号	弹簧规格	弹簧力N (kgf)			备注	
		θ	初压	下死点前5mm 终压		
GK	K500-064	—	—	6125(625)	—	
ISO	φ50×178	00	749(76.4)	3910(398.7)	4494(458.3)	矩形弹簧(常数=74.9N/mm)
		05		3970(404.8)		
		10		4015(409.4)		
		15		4052(413.2)		
		20		4090(417.0)		
		25		4120(420.1)		
		30		4149(423.1)		
		35		4179(426.2)		
40	4202(428.5)					
45	4232(431.5)					
NGK	—	—	—	—	无氮气弹簧	
NISO	—	—	—	—	无矩形弹簧	



Order 订货范例

Catalog No. MEFNS W - θ - 弹簧型号
200 - 15 - ISO



Alterations 追加加工

Catalog No. MEFNS W - θ - 弹簧型号 - (N·NF)
200 - 05 - NGK - N
详情请见 MISUMI 网站。
(<https://www.misumi.com.cn>)



Delivery 交货期

请通过 MISUMI 询价。
(<https://www.misumi.com.cn>)

Alterations	Code	Spec.
	N	定位销孔加工 在底座上加工2处φ16H7定位销孔。
	NF	氮气弹簧不充入氮气 仅适用于弹簧型号GK