

## MEFNS80

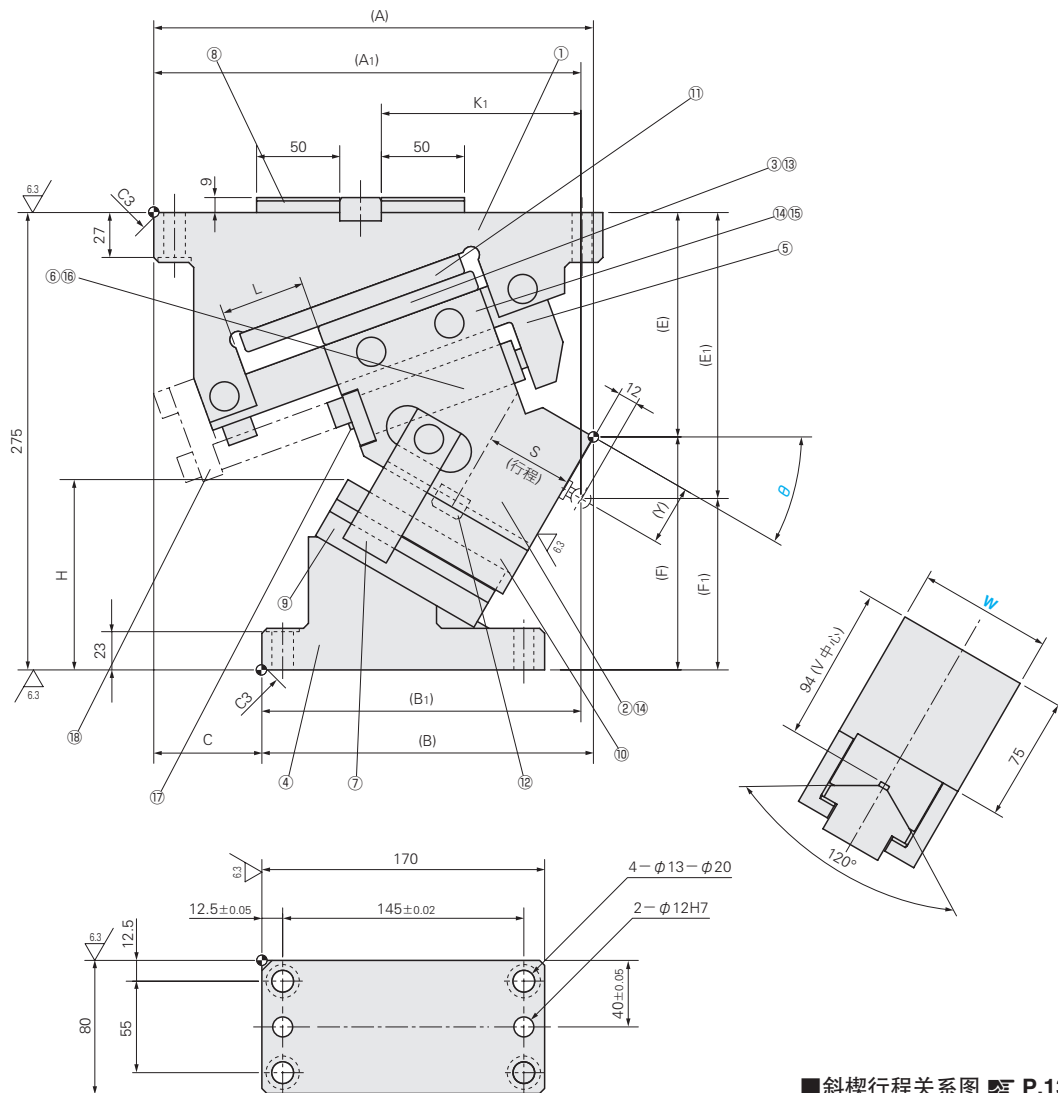
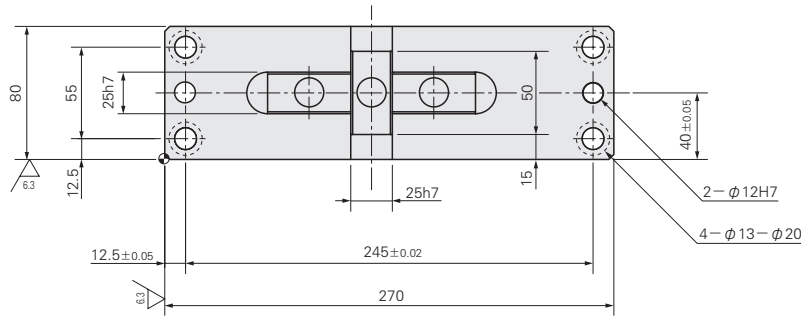

■斜楔行程关系图 P.1343  
■构成零件表 P.1347

W	θ	A	A <sub>1</sub>	B	B <sub>1</sub>	C	E	E <sub>1</sub>	F	F <sub>1</sub>	H	L	K <sub>1</sub>	Y
80	00	280	292	145	157	135	110	155	165	120	69	50	180	45
	05	281.31	289.5	156.31	164.5	125	115.93	160	159.07	115	73.5		160.5	43.19
	10	277.5	281.37	167.5	171.37	110	117.84	165	157.16	110	82.6		153	45.77
	15	280.48	279.7	175.48	174.7	105	120.72	170	154.28	105	91.3		144	47.8
	20	276.16	270.57	181.16	175.57	95	124.55	175	150.45	100	99.6		136.5	49.32
	25	271.47	261.07	191.47	181.07	80	129.29	180	145.71	95	107.3		127.5	50.35
	30	264.33	249.27	199.33	184.27	65	134.92	185	140.08	90	114.5		120	50.9
	35	260.66	241.26	205.66	186.26	55	141.38	190	133.62	85	120.9		112.5	50.95
	40	252.32	228.34	217.32	193.34	35	147.76	195	127.24	80	126.8		105	51.6
	45	247.46	221.04	217.46	191.04	30	156.61	200	118.39	75	131.8		99	49.36
	50	237.8	209.12	222.8	194.12	15	165.27	205	109.73	70	136.1		93	47.51
	55	231.36	201.62	231.36	201.62	0	174.53	210	100.47	65	139.6		72	44.7
60	233.95	207.53	233.95	207.53	185.89		215	89.11	60	140.7	40	79	37.43	

行程 S	加工力KN (tonf)	总重量 kg	Catalog No.	W	θ	弹簧型号
32.1	166.7 (17.0)	27.9	MEFNS	80		*00
35.5		27.5				*05
38.9		26.9				*10
42.4		26.5				15
46.1		26.0				20
50.0		25.9				25
54.3		25.3				30
59.0		25.0				35
64.3		24.7				40
70.4		24.7				*45
77.8		24.9				50
78.5		25.8				55
80.0		26.2				60

### ■弹簧类型

弹簧型号	弹簧规格	弹力N (kgf)			备注
		θ	初压	下死点前5mm 终压	
GK	M2-50-Red	-	-	2350 (240.0)	-
ISO	φ32×152	00	-	1044(106.5)	1224 (124.8) 矩形弹簧 (常数=23.0N/mm)
		05	-	1063(108.4)	
		10	-	1076(109.8)	
		15	-	1088(110.9)	
		20	-	1099(112.1)	
		25	-	1109(113.0)	
		30	74	1118(114.0)	
		35	(7.5)	1127(114.9)	
		40	-	1134(115.6)	
		45	-	1143(116.6)	
		50	-	1150(117.3)	
		55	-	1042(106.2)	
60	-	936(95.5)	994 (101.3)		
NGK	-	-	-	-	无氮气弹簧
NISO	-	-	-	-	无矩形弹簧

Order 订货范例 Catalog No. **MEFNS** W - **80** - θ - **30** - 弹簧型号 **ISO**

Delivery 交货期

- 带\*符号
- 库存品
- 隔日上海·广州发货 P.41
- 数量≥5时, 请另询交货期。
- 上述以外, 请通过 **MISUMI** 询价。  
(<https://www.misumi.com.cn>)

Alterations 追加加工

Catalog No. **MEFNS** W - **80** - θ - **05** - 弹簧型号 **GK** - (NF)

Alterations Code **NF** Spec. 氮气弹簧不充入氮气  
仅适用于弹簧型号GK