

無給油ヒールガイドプレート
自潤滑外導板

油溝付ヒールガイドプレート
油槽型外導板

RoHS10

RoHS10

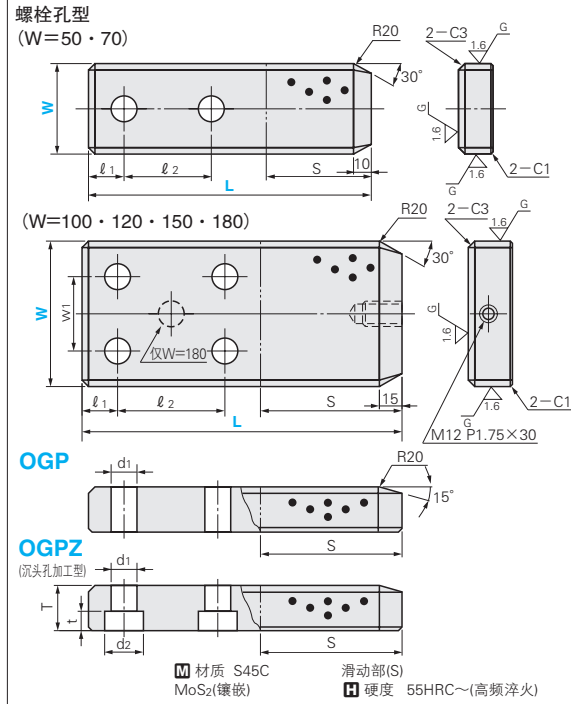
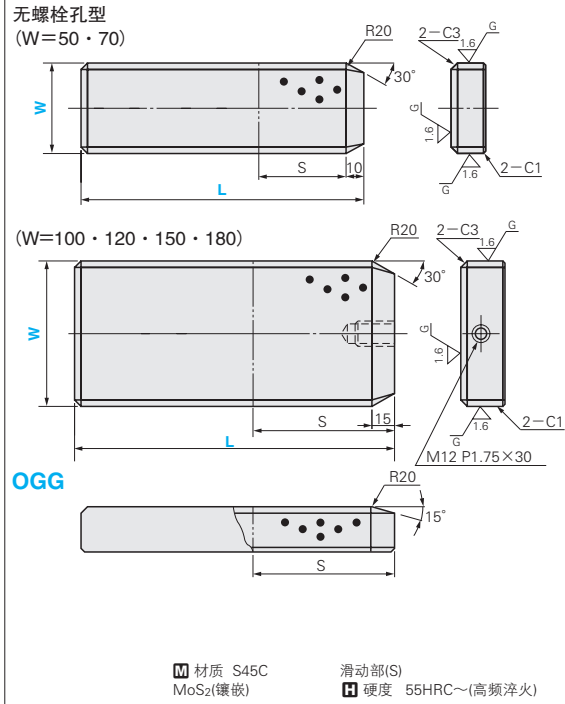
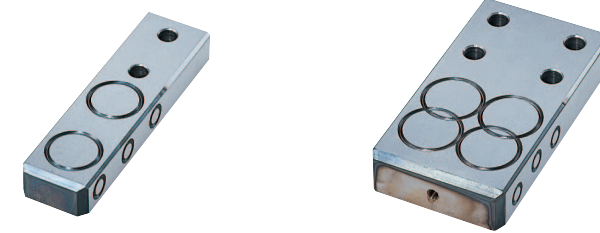
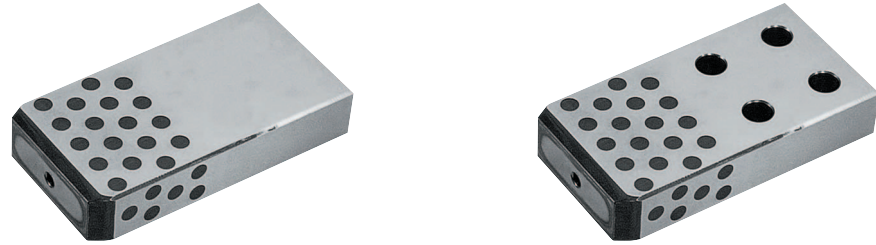

W	T	S	OGP・OGPZ				Catalog No.		L	
			l ₁	l ₂	w ₁	d ₁	Type	W		
50	0 -0.025	30	60	50	18	26	18	160	50	
			120	50						200
			120	80						260
70	0 -0.030	35	100	60	18	26	18	230	70	
			160	60						260
			160	75						300
100	0 -0.035	45	100	60	18	26	18	230	100	
			160	60						280
			160	100						330
120	0 -0.035	45	100	60	18	26	18	230	120	
			160	60						280
			160	100						330
150	0 -0.040	50	100	60	18	26	18	230	150	
			160	60						280
			160	100						330
180	0 -0.040	55	100	60	18	26	18	230	180	
			160	60						280
			160	100						330

Order 订货范围 Catalog No. - L
OGP 50 - 160

Delivery 交货期 20 天发货
上海・广州发货
数量≥51时, 请另询交货期。

- 请在加油后使用。(润滑脂)
- 内置于槽中的特殊固体润滑剂具有可根据负载持续补充润滑剂的特性。
- 滑动方向只限于L尺寸方向。

OGG
OGP
OGPZ

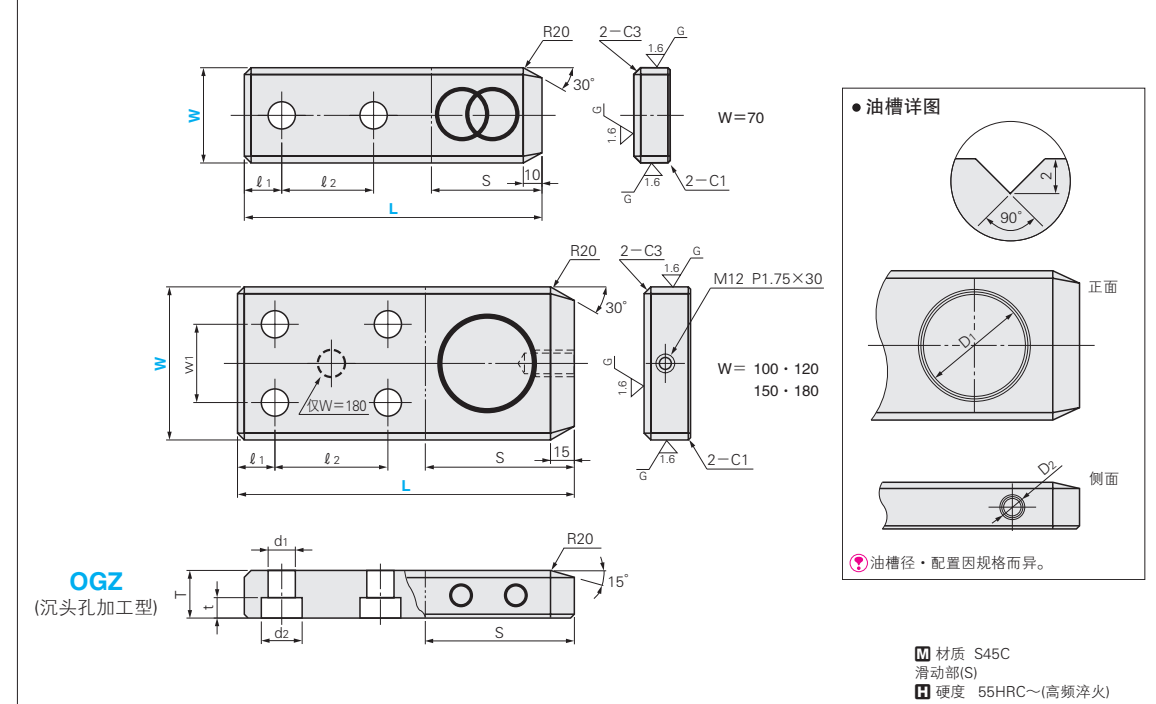

W	T	S	l ₁	l ₂	w ₁	d ₁	d ₂	t	油槽		Catalog No.		L
									正面 数量	D1	侧面 数量	D2	
70	0 -0.030	35	100	25	60	18	26	18	2	50	各2	20	70
			160	60	各3				20				
			160	75	各3				20				
100	0 -0.035	45	100	30	60	18	26	18	1	63	各2	20	100
			160	60	各3				20				
			160	100	各3				20				
120	0 -0.035	45	100	30	60	18	26	18	2	50	各2	20	120
			160	60	各3				20				
			160	100	各4				20				
150	0 -0.040	50	100	30	60	18	26	18	4	50	各3	20	150
			160	60	各3				20				
			160	100	各4				20				
180	0 -0.040	55	100	30	60	18	26	18	4	63	各3	20	180
			160	60	各4				20				
			160	100	各3				20				

Order 订货范围 Catalog No. - L
OGZ 100 - 230

Delivery 交货期 11 天发货
上海・广州发货
数量≥51时, 请另询交货期。