

PD 适用导柱直径	D	M×P	B	t	D1	D2	② 附件 弹簧垫片	Catalog No. Type	L 钢球衬套长度
20	24	10×1.5	5	1.6	19	14	根据 JIS B1251-1984 的公称为8mm	STM (可动挡块)	20
22	26	12×1.5	6		21				22
25	29				24				25
28	33	16×1.5	8		27				28
32	37			31	32	75			90
38	44			37	38	75			90
45	51			44	45	90			110
50	56	66		49	50	90			110
60	66			59	60	90	110		

L 钢球衬套长度	STM S	STM l	STK l	①CB	Order 订货范例	Catalog No.	L	Delivery 交货期	库存品
50	0~19	31	15	8-30	STM 32	90			
60	0~23	35	20	8-35					
75	0~30	42	25	8-40					
90	0~37	49	30	8-45					
110	0~47	59	35	8-50					

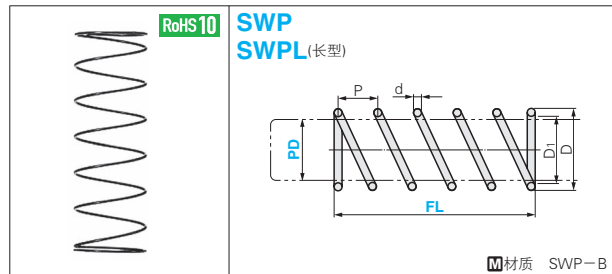

PD 适用导柱直径	D	D1 +1 0	d	P
20	22.5	20.5	1.0	14
22	24.5	22.5	1.0	14
25	27.9	25.5	1.2	14
28	31.3	28.5	1.4	16
32	35.7	32.5	1.6	16
38	42.5	38.5	2.0	18
45	50.1	45.5	2.3	20
50	55.7	50.5	2.6	20
60	66.9	60.5	3.2	20

Order 订货范例 Catalog No. - FL
SWP 32 - 100

Delivery 交货期 库存品

• SWP
① 隔日上海·广州发货 P.41 (17:00前订购的库存品可当日发货。)
② 数量≥201时，请另询交货期。

• SWPL(长型)
7 天发货
① 上海·广州发货
② 数量≥51时，请另询交货期。

• 压紧长度 = $\frac{FL \times d}{P} + 2d$

Catalog No. Type	PD	FL 指定单位10mm
SWP	20	40~90 100~140
	22	40~90 100~140
	25	40~90 100~150
	28	50~90 100~150
	32	70~140 150~190
	38	80~140 150~190
SWPL (长型)	45	80~140 150~190
	50	80~140 150~190
	60	80~140 150~190
	20	150~190 200~240
	22	150~190 200~240
	25	160~200 210~260

Catalog No. Type	PD	FL 指定单位10mm
SWPL (长型)	28	160~200 210~260
	32	200~220 230~260
	38	200~240 250~300
	45	200~240 250~300
	50	200~240 250~300
	60	200~240 250~300

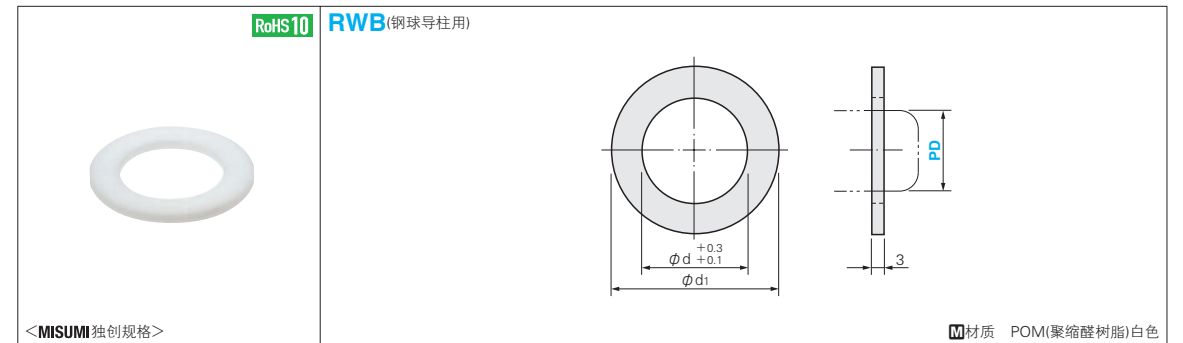

内径 d	外径 d1	公差	Catalog No. Type	PD
20	35	+1.5	RWB (钢球导柱用)	20
22	35	+0.3		22
25	40	+0.5		25
28	45			28
32	50	+2.0		32
38	60	+3.0		38
45	70		+1.0	45
50	75	+4.0	50	
60	85		+1.5	60

■特 长 通过弹簧的推力防止钢球衬套上跳，可延长导柱&导套的使用寿命。

