

ダイセット用ボールガイドポストセット - 圧入ポスト -
模架用钢球导柱组件
 - 压入型 -

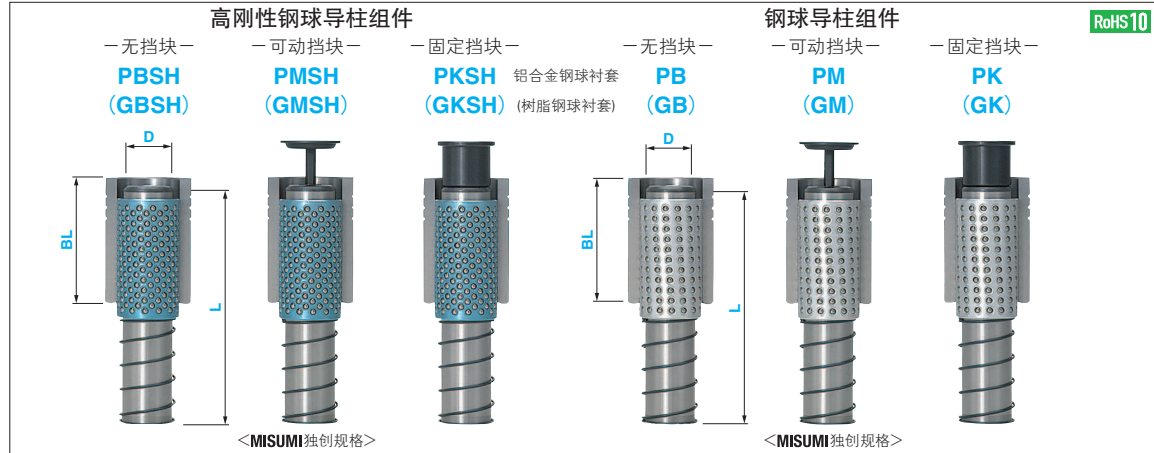

※组件时仅为规格尺寸。
 订购非规格尺寸零件时，请
 在各零件单上指示追加工
 及订购 (P.947~949)。

◆导柱采用高频淬火，中心无硬度，安装请勿使用硬物敲击。



RoHS10

Catalog No.	构成零件					
	①	②	③	④	⑤	⑥
PBSH	MSP		MBSH			
PMSH	BSPM		MBSH		STM	
PKSH	BSPK		LBB	SWP		STK
GBSH	MSP		LBB	SWP		
GMSH	BSPM		MBJH		STM	
GKSH	BSPK					STK
PB	MSP		MBS			
PM	BSPM		MBS		STM	
PK	BSPK		LBB	SWP		STK
GB	MSP		LBB	SWP		
GM	BSPM		MBJ		STM	
GK	BSPK					STK

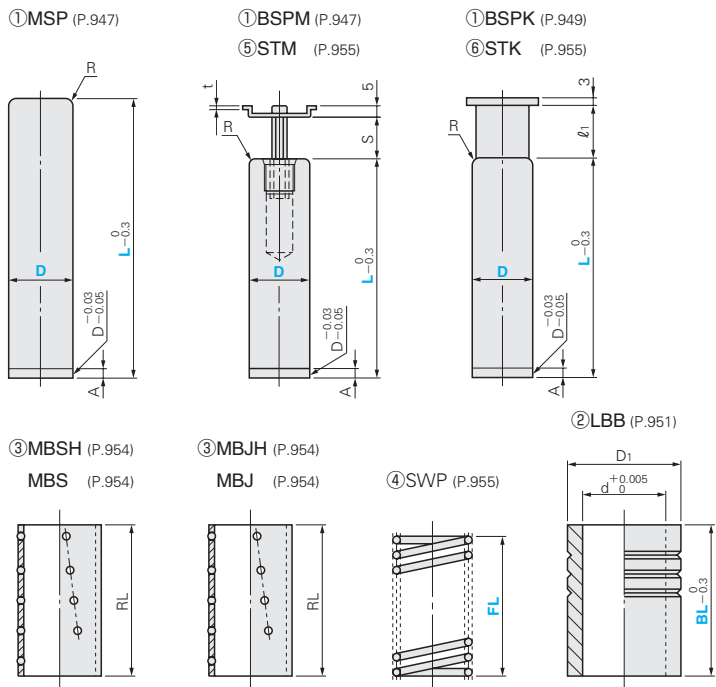

MSP・BSPM・BSPK				
D	A	R	t	
20	+0.020	2.0		1.6
22	+0.015	3.0		
25				
28	+0.025	5	3.5	2.0
32	+0.020	6	4.0	
38	+0.030	7	5.0	
45	+0.025			
50	+0.035			
60	+0.030			

LBB		
d	D1	D1□
26	37	
28	40	0
31	45	-0.007
36	50	
40	55	
48	64	0
55	74	-0.008
60	83	0
70	95	-0.010

RL	S	l1
50	0~19	15
60	0~23	20
75	0~30	25
90	0~37	30
110	0~47	35

■导套安装方法

LBB	LOCTITE粘接	LOCTITE No.638 (LOC638)
-----	-----------	-------------------------

■高刚性钢球导柱组件

使用钢球数1.6倍于普通钢球衬套的高刚性钢球衬套(MBSH・MBJH)，以低成本实现了接近于滑动导柱的刚性。

Catalog No.	Type	D	L																②LBB		RL	FL 指定单位10mm
																			Type	BL		
PBSH PMSH PKSH GBSH GMSH GKSH PB PM PK GB GM GK		20	100	110	120	130	140	150	160	170	180	L (LBB)	50	50	50	40~140						
		22	120	130	140	150	160	170	180	50	50			40~140								
		25	120	130	140	150	160	170	180	60	60			40~150								
		28	140	150	160	170	180	190	200	60	60			50~150								
		32	160	170	180	190	200	220	240	75	75			50~150								
		38	180	190	200	220	240	260	80	75	70~190											
		45	180	190	200	220	240	260	80	75	80~190											
		50	200	220	240	260	100	90	80~190													
		60	200	220	240	260	100	90	80~190													
															120	110	80~190					
												100	90	80~190								
												120	110	80~190								
												100	90	80~190								
												120	110	80~190								



Delivery 交货期
 库存品
 隔日上海・广州发货 (P.41)
 (17:00前订购的库存品可当日发货。)
 数量≥51时，请另询交货期。

Type	材质	硬度	表面处理
MSP BSPM BSPK	M SUJ2 M S45C (安装盖)	H 58HRC~	S 高频淬火
STM	M S45C	S 四氧化三铁保护膜(Fe3O4)	
STK	M S45C	S 四氧化三铁保护膜(Fe3O4)	附件 CB

Type	材质	硬度
LBB	M SUJ2 H 58HRC~	
MBSH MBS	M A5056 (铝合金)	

Type	材质
MBJH MBJ	M POM (聚酯树脂)
SWP	M SWP-B

模架用
导柱·导套