

方形导向顶杆

ー装卸型ー

交货期短缩

方形导向顶杆

ー键止动型ー

交货期短缩

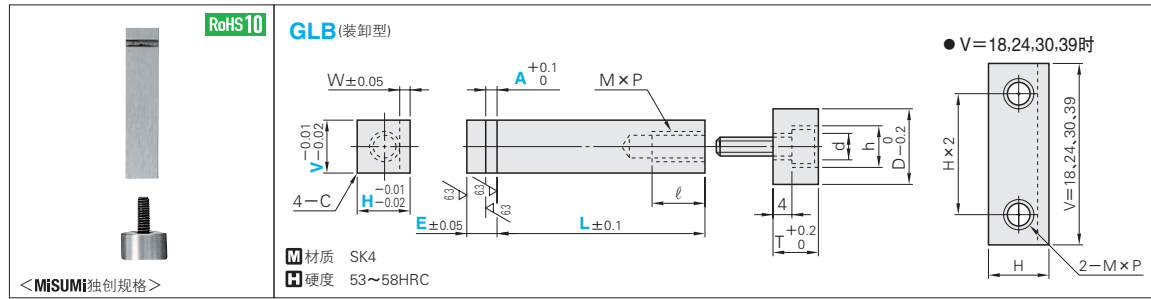

W	C	M×P	ℓ	D	d	T	h	Catalog No.	V	H	指定单位0.1mm		
											L	A	E
1.5	0.5	3×0.5	9	10	4	7	6.5	GLB	5	5	20.0~60.0	0.5~3.6	5.0~15.0
									6	6			
									8	8			
									10	10			
2.0	0.8	4×0.7	12	14	5	8	8	GLB	13	13	26.0~80.0	0.5~3.6	5.0~15.0
									13	13			
2.5		5×0.8	15	18	6	9	9.5						

Order 订货范例 Catalog No. V H L A E
GLB 08 08 40.0 2.0 6.0

Delivery 交货期 7 天发货
① 上海·广州发货
② 数量≥201时, 请另询交货期。

Catalog No. V H L A E (WC)
GLB 08 08 40.0 2.0 6.0 WC2.0

Alteration	Code	Spec.	
		H	WC
	WC	变更WR尺寸 指定单位0.1mm	
		5	1.0~1.5
		6	1.0~2.0
		8	1.0~3.0
		10	1.0~3.5
13	1.5~4.5		

Example 使用范例

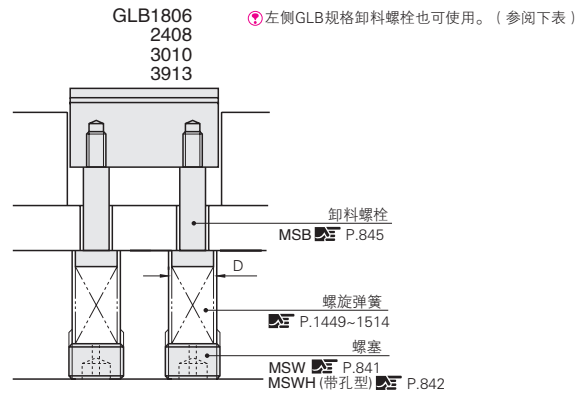
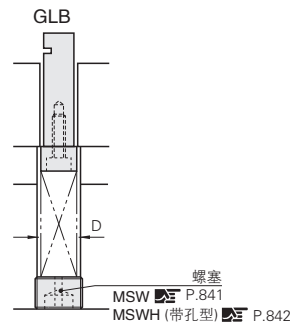

■建议的螺旋弹簧·螺塞对应表

导向顶杆	螺旋弹簧		螺塞
	Type	D	
GLB 0505	WR	10	MSW12
GLB 0606	WF	10	MSW12
GLB 0808	WL	13	MSW16
GLB 1010	WT	16	MSW20
GLB 1313	WM	18	MSW20
GLB 3913	WH	18	MSW20

■建议的螺旋弹簧·螺塞·卸料螺栓对应表

导向顶杆	卸料螺栓	螺旋弹簧 D	螺塞
GLB1806	MSB4.5	8	MSW10
GLB2408	MSB5.5	10	MSW12
GLB3010	MSB6	10	MSW12
GLB3913	MSB6.5	10	MSW12

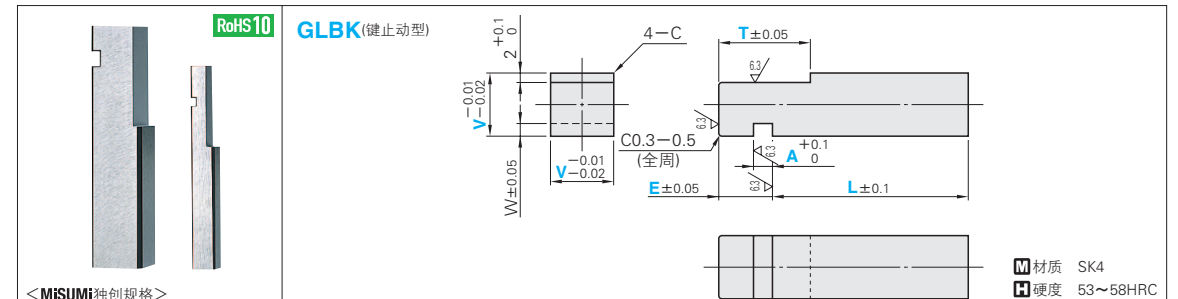

W	Catalog No. Type	V	指定单位5mm		指定单位0.1mm	
			L	A	E	T
1.5	GLBK	6	30~80	0.5~4.0	5.0~25.0	5.0~50.0 ※T≥E ※T≤(L+E)/2
		8				
		10				
		13				
2.0						
2.5						

Order 订货范例 Catalog No. L A E T
GLBK 8 35 2.3 8.6 20.5

Delivery 交货期 7 天发货
① 上海·广州发货
② 数量≥201时, 请另询交货期。

■特长
通过调整T尺寸, 可调整顶料量。
另外, 根据E尺寸的调整, 卸料板可进行冲孔加工。

Catalog No. L A E T (WC)
GLBK 8 35 1.0 8.6 20.5 WC2.0

Alteration	Code	Spec.	
		V	WC
	WC	变更WR尺寸 指定单位0.1mm	
		6	1.0~2.0
		8	1.0~3.0
		10	1.0~3.5
13	1.5~4.5		

