

**RoHS10 MSRB** (MSB用衬垫)

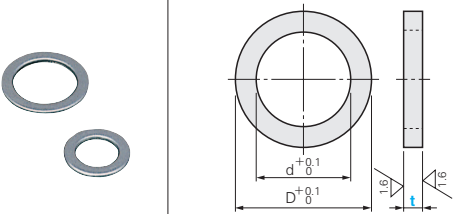

**RoHS10 SW** (卸料螺栓用・螺旋弹簧用垫圈)

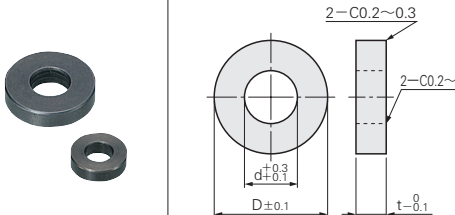

**RoHS10 K・W** (内螺纹固定型卸料螺栓用衬垫)

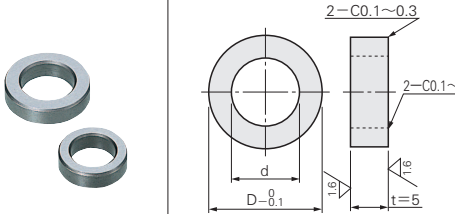

**RoHS10 T・R** (衬套型卸料螺栓用衬垫)

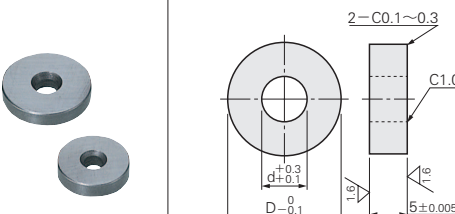

**材质** SK5  
**材质** S45C  
**硬度** 48~52HRC  
**材质** S45C  
**硬度** 48~52HRC  
**材质** S45C  
**硬度** 48~52HRC  
**材质** S45C  
**硬度** 48~52HRC

t	D	d	Catalog No.	t
0.1 ±0.020	6.5	4	*4	0.1
0.2 ±0.020	7	4.5	4.5	
0.3 ±0.030	8	5	*5	
0.5 ±0.030	9	5.5	5.5	
1.0 ±0.040	9	6	*6	
2.0 ±0.090	10	6.5	6.5	
	13	8	8	
	16	10	10	
	17	12	*12	
	18	13	13	
	24	16	16	
	27	20	20	

带有\*符号的尺寸没有t=2.0规格。

D	d	t	Catalog No.
10	4.5	3	10
12	5.5		12
16	6		12-6
16	6.5	4	16
20	8		20
22	10	5	22
25	12		25
27	13		25-12
30	13	8	27
35	16		30
40	16		35
50	20	10	40
			50

t	D	d	Catalog No.
±0.005	10	6	K
	13	8	
	16	10	
	20	12	
±0.01	8	5	W
	11	6	
	14	8	
	17	10	
	17	10	

D	d	Catalog No.
11.5	4	6.5
13	5	8
15	6	10
18	8	13
21	10	16
23	12	20
16	4	6.5-16
18	4	6.5-18
18	5	8-18
20	5	8-20
22	5	8-22
20	6	10-20
22	6	10-22
25	6	10-25
27	6	10-27
25	8	13-25
27	8	13-27
30	8	13-30
30	10	16-30
35	10	16-35
40	10	16-40
35	12	20-35
40	12	20-40

**Order 订货范例**

• MSRB  
Catalog No. - t  
MSRB 10 - 0.1

• SW・K・W・T・R  
Catalog No.  
SW 25  
K 10  
W 16  
T 10  
R 10-20

**Delivery 交货期**

• MSRB・SW・T・R・W  
库存品  
隔日上海・广州发货 (17:00前订购的库存品可当日发货。)  
数量≥1001时, 请另询交货期。

• K  
9天发货  
上海・广州发货  
数量≥1001时, 请另询交货期。

**RoHS10 J** (带沉头孔衬套型卸料螺栓用衬垫)

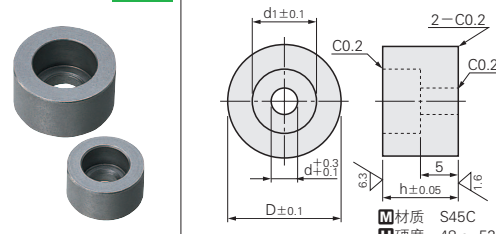

**RoHS10 LRB** (导向顶杆・顶出销用衬垫)

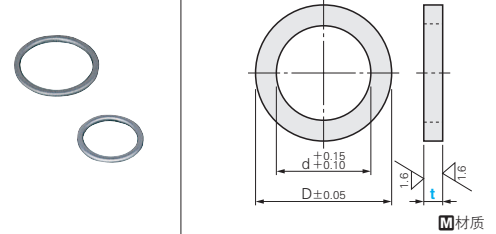

**RoHS10 SRW** (卸料板导柱用垫圈)

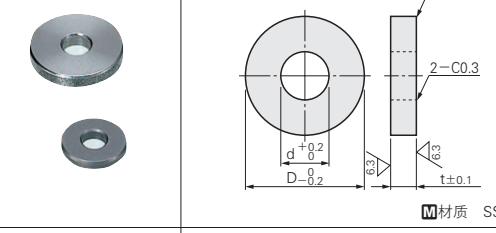

**RoHS10 SBW** (顶杆・吊装轴环用垫圈)

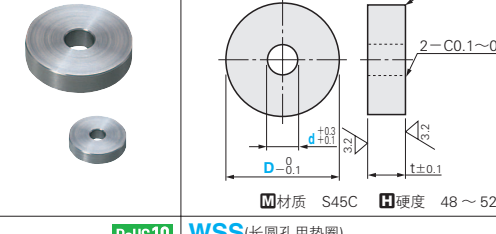

**RoHS10 WSS** (长圆孔用垫圈)

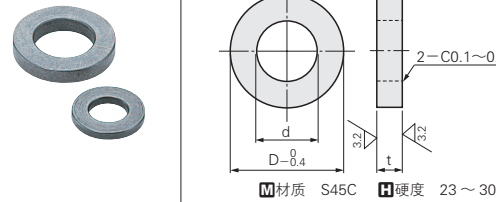

**材质** S45C  
**硬度** 48~52HRC  
**材质** S45C  
**硬度** 48~52HRC  
**材质** SS400  
**材质** S45C  
**硬度** 48~52HRC  
**材质** S45C  
**硬度** 23~30HRC

**Order 订货范例**

• J・SRW・WSS Catalog No. - t・d  
J 16  
SRW 20  
WSS 8

• LRB・SBW Catalog No. - t・d  
LRB 8 - 0.5  
SBW 27 - 8

**Delivery 交货期**

库存品  
隔日上海・广州发货 (17:00前订购的库存品可当日发货。)  
数量≥1001时, 请另询交货期。

D	d1	d	h	Catalog No.
12	8	4	9	J
14	10	5	10	
18	11	6	11	
24	14	8	13	
27	17.5	10	15	
32	19.5	12	17	
				8
				10
				13
				16
				20

t	D	d	Catalog No.	t	
0.1 ±0.020	6	4	LRB	4	
0.2 ±0.020	7	5		5	
0.3 ±0.030	8	6		6	
0.5 ±0.030	10	8		8	
1.0 ±0.040	13	10		10	
	16	13		13	
	19	16		16	
	23	20		20	
					0.1
					0.2
				0.3	
				0.5	
				1.0	

D	d	t	Catalog No.
12	5.3	3	SRW
15	5.3	3	
19	6.4	4	
22	6.4	4	
26	8.4	5	
30	8.4	5	
			8
			10
			13
			16
			20
			25

t	Type	D	d
5	SBW	20	5
		22	5
		25	6
		27	5
7	SBW	30	6
		35	6
		35	8

D	d	t	Catalog No.	
12.5	6.4	+0.25 0	WSS	
17	8.4	2.5 ±0.25		
21	10.5	3 ±0.3		
24	13	4 ±0.4		
30	17	5 ±0.5		
37	21	5 ±0.5		
				6
				8
				10
				12
			16	
			20	

**Example 使用范例**

