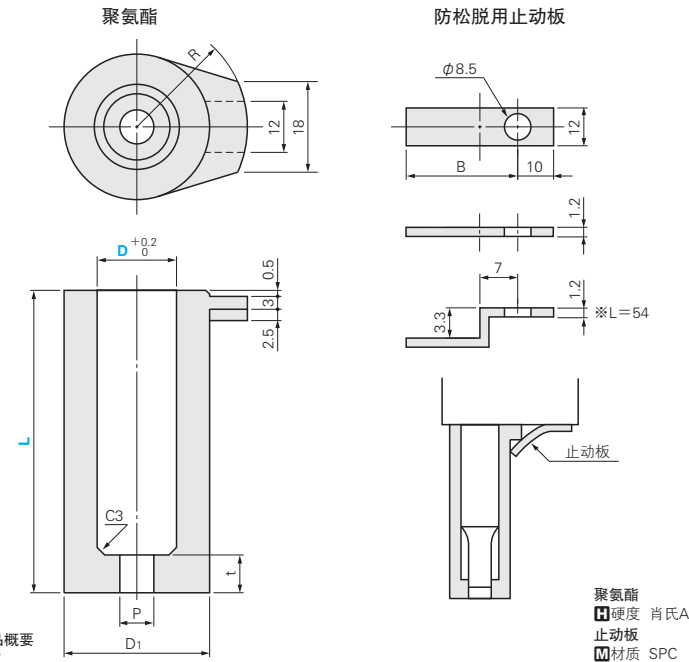

RoHS 10 TUS

聚氨酯  
防松脱用止动板

聚氨酯  
硬度 肖氏A95  
止动板  
材质 SPC

聚氨酯产品概要 P.1577

D	D1	R	P	t	B	固定块 适用类型	N(kgf)负载		Catalog No.	
							F=L×10%	F=L×15%	Type	D-L
10	18	13	3.5	6	16	—	981{100}	1373{140}	TUS	10-54
					17.5	②				10-59
					24.5	①				10-61
					17.5	②				10-66A
					24.5	①				10-66B
13	23	15.5	3.5	6	17.5	②	1569{160}	1961{200}	13-59	
					22.0	①			13-61	
					17.5	②			13-66A	
15	25	16.5	4	6	12.5	—	1863{190}	2256{230}	13-66B	
					17.5	②			15-54	
					17.5	②			16-59	
16	28	18	4	6	17.5	②	2452{250}	2942{300}	16-66	
					12.5	—			20-54	
					17.5	②			20-59	
20	33	20.5	4	7	17.5	②	3040{310}	3727{380}	20-66	
					17.5	②			25-59	
					20.5	②			25-59	
25	40	24	4	7	20.5	②	4119{420}	5099{520}	25-66	
					20.5	②			25-66	

固定块适用类型: ①单螺栓固定型 P.759・760 ②三角型 P.765・766

负载(kgf)=负载N×0.101972

Order 订货范例 Catalog No. TUS 10-59

Delivery 交货期 5 天发货

聚氨酯卸料板在模具调整时先进行空打，待形状与凸模刃口一致后再使用。(非圆形凸模也可以使用。)

①上海・广州发货  
②数量≥201时，请另询交货期。

■适用于TUS的固定块

类型	适用固定块
①	• SP-APS • SPARS ... P.759
	• SP-FPS • SPFRS ... P.760
	• TP-APS • TPARS ... P.760
②	• 25CRN-AP • 25CRNAR ... P.765
	• 25CRN-FP • 25CRNFR ... P.765
	• CRN-AP • CRNAR ... P.766

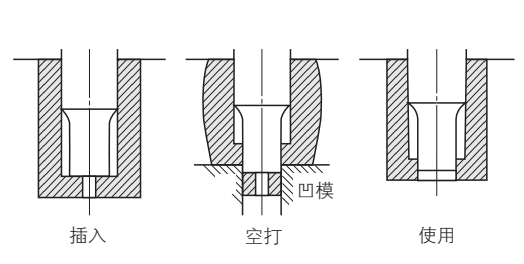

RoHS 10 USN

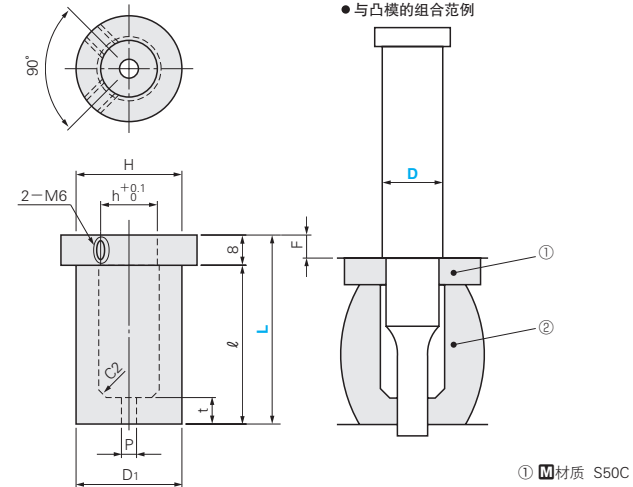
与凸模的组合范例

聚氨酯产品概要 P.1577

①材质 S50C  
②硬度 肖氏A95

F=l×10%		F=l×15%		F=l×20%		适用凸模直径 D	D1	P	t	h	H	L	Catalog No.					
Fmm	N(kgf) 负载	Fmm	N(kgf) 负载	Fmm	N(kgf) 负载								Type	公称尺寸				
3.2	1226 {125}	4.8	1569 {160}	6.4	1863 {190}	10	18	3.5	6	9.2	23	40	USN	10				
4.2	{200}	6.3	{250}	8.4	{300}	13	23								40	23	50	13
3.2	1961 {200}	4.8	2452 {250}	6.4	2942 {300}	16	28											
4.2	{280}	6.3	{360}	8.4	{430}	20	33	40	33	50	20							
3.2	2746 {280}	4.8	3530 {360}	6.4	4217 {430}	25	40					40	40	50	25			
4.2	{340}	6.3	{430}	8.4	{510}	32	50									40	50	50
3.2	5099 {520}	4.8	6472 {660}	6.4	7453 {760}	40	40	7	24.2	40	40							
4.2	{800}	6.3	{1000}	8.4	{1150}							40	50	5	31.2			
3.2	7845 {800}	4.8	9807 {1000}	6.4	11278 {1150}											50	50	5
4.2	{800}	6.3	{1000}	8.4	{1150}	50	50	5	31.2	50	40							

负载(kgf)=负载N×0.101972

Order 订货范例 Catalog No. USN 16-50

Delivery 交货期 库存品

隔日上海・广州发货 P.41 (17:00前订购的库存品可当日发货。)

数量≥201时，请另询交货期。

先进行空打，待形状与凸模刃口一致后再使用。(非圆形凸模也可以使用。)

凸模必须进行聚氨酯卸料板安装加工(追加工代码UC)。

