

弯曲凹模

— 螺栓固定型 —



交货期短縮

肋用凸模



交货期短縮

RoHS10

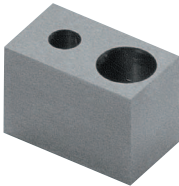

BBMD

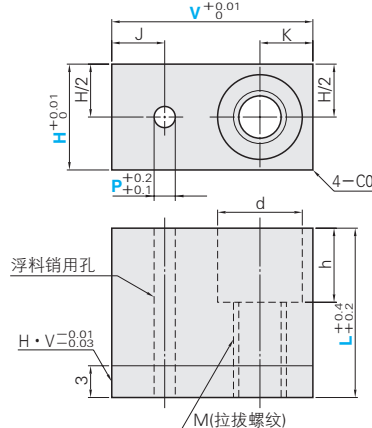

拉拔螺栓高于安装螺栓一个规格。

安装螺栓	M(拉拔螺栓)
M3	M4
M4	M5
M6	M8
M8	M10

M 材质 相当于SKD11
H 硬度 60~63HRC

Example 使用范例



K	安装螺栓规格			J	Catalog No.	V	H	L	P
	d	h	规格						
4	6	7.5	M3	3	BBMD	13	8	16	2
				4		16			
				5		18			
				6.5		20			
				8		25			
5	8	8.5	M4	4	BBMD	18	10	20	4
				5		20			
				6.5		22			
				8		25			
				10		30			
6.5	11	10.5	M6	5	BBMD	22	13	25	6
				6.5		25			
				8		28			
				10		32			
				12.5		38			
8	14	12.5	M8	8	BBMD	32	20	30	8
				10		35			
				12.5		40			
				15		45			
				17.5		50			

Order 订货范例

(1) 浮料销用孔的中心位置为通常(J, H/2)位置时
 Catalog No. **V H - L - P**
BBMD 25 13 - 20 - P2

(2) 浮料销用孔的位置为指定(X, Y)时
 Catalog No. **V H - L - P - X - Y**
BBMD 25 13 - 20 - P2 - X4.60 - Y3.20

指定单位0.01mm

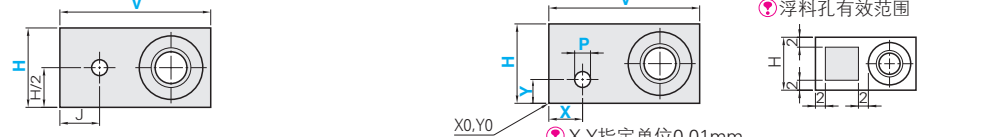

Delivery 交货期 **7** 天发货

上海·广州发货
 数量 ≥ 101 时, 请另询交货期。

Alterations 追加加工
 Catalog No. **V H - L(LC) - P** (PKC·CC...etc.)
BBMD 25 13 - LC18.0 - P2 - PKC

Alterations	Code	Spec.
	LC	变更全长 16 < LC < 35 指定单位0.1mm(LKC并用时, 指定单位可为0.01mm)
	PKC	变更P尺寸公差 P ^{+0.2} / _{+0.1} ⇒ P ^{+0.10} / _{+0.05}
	CC	V·H的4个角做C0.5倒角处理
	LKC	变更全长公差 L ^{+0.4} / _{+0.2} ⇒ L ^{+0.05} / ₀
	VKC1	变更V·H公差 V·H ^{+0.01} / ₀ ⇒ V·H ^{+0.005} / ₀
	VKC2	变更V·H公差 V·H ^{+0.01} / ₀ ⇒ V·H ⁰ / _{-0.005}
	NDC	无导入部

RoHS10



RASP

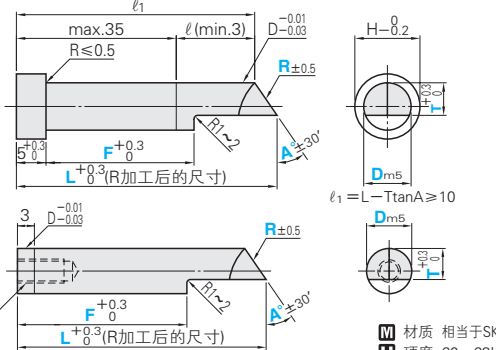

沉头用

Example 使用范例

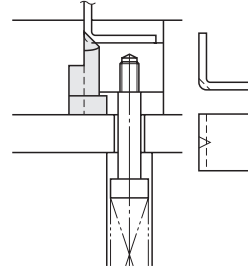

H	M × l ₂	Catalog No.		指定单位0.1mm		选择		
		Type	D	L	T	A	R	F
11	4 × 8	RASP RAMP	8	25~70	D/2 ≤ T ≤ D-2	30	1 ≤ R ≤ 5 或R0	0 ≤ F ≤ L/2 L/2 + 6 ≤ F ≤ L
13	5 × 10		10	30~70				
16	6 × 12		13	30~70				
19			16	35~70				
23			20	40~70				
28		25	45~70					

RoHS10



RBSP

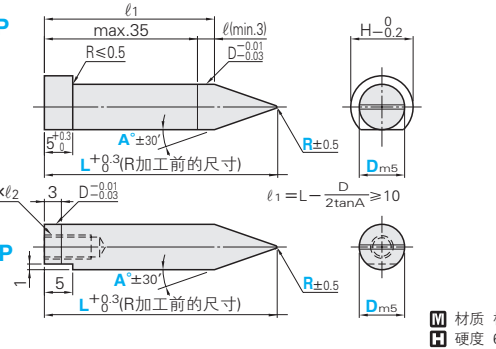

V形弯曲用

Example 使用范例

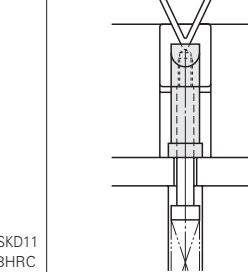

H	M × l ₂	Catalog No.		指定单位0.1mm		指定单位1°	
		Type	D	L	A	R	
11	4 × 8	RBSP RBMP	8	20~70	A ≥ 20	0.5 ≤ R ≤ 5 或R0	
13	5 × 10		10	30~70			
16	6 × 12		13	30~70			
19			16	40~70			
23			20	40~70			
28		25	40~70				

Order 订货范例

• 沉头用
 Catalog No. **L - T · A · R · F**
RASP 10 - 50.0 - T5.0 - A60 - R1.0 - F20.0

• V形弯曲用
 Catalog No. **L - A · R**
RBSP 10 - 50.0 - A30 - R0.5

Delivery 交货期 **7** 天发货

上海·广州发货
 数量 ≥ 101 时, 请另询交货期。

Alterations 追加加工
 Catalog No. **L - T · A · R · F** (HC·TC...etc.)
RASP 10 - 50.0 - T5.0 - A60 - R1.0 - F20.0 - HC12.0 - TC4.0

Alterations	Code	Spec.	Alterations	Code	Spec.
	HC	变更凸缘直径 D ≤ HC < H 指定单位0.1mm		WKC	止回平行加工(双面) • RASP · RAMP
	TC	变更凸缘厚度 2 ≤ TC < 5 指定单位0.1mm		SKC	• RBSP · RBMP 杆部平面加工
	KC	止回单面加工·变更位置 • RASP · RBSP 指定单位1° 180° 90° -270° • RAMP · RBMP 指定单位1° 180° 90° -270°			