

安装螺栓 M	V	H	P	B	Catalog No.		A	L	文字(粗体) CHR
					Type	文字数			
6	16	22	3.5	2	OCP	3M	3	20	0 1 2 3 4 5 6 7 8 9 A B C D E F G H I J K L M N O P Q R S T U V W X Y Z
						4M			
						5M			
						6M			
6	25	10	3.5	2	BCP	3M	3	20	(注1) [] (空格) (注2) - (连字号)
						4M			
						5M			
						6M			
8	25	13	6.0	4	VCF	3M	6	25	
						4M			
						5M			
						6M			

(注1)请用%指定 [] (空格)。 (注2)请用#指定 - (连字号)。

Order 订货范例 Catalog No. - [A] - [L] - [CHR] 刻印的配置范例
 OCP3M - 3 - 20 - ABC
 OCP3M - 3 - 25 - %AB
 OCP4M - 3 - 20 - ABCD
 OCP4M - 3 - 25 - A#B%

Delivery 交货期 5 天发货
 上海·广州发货
 数量≥101时, 请另询交货期。

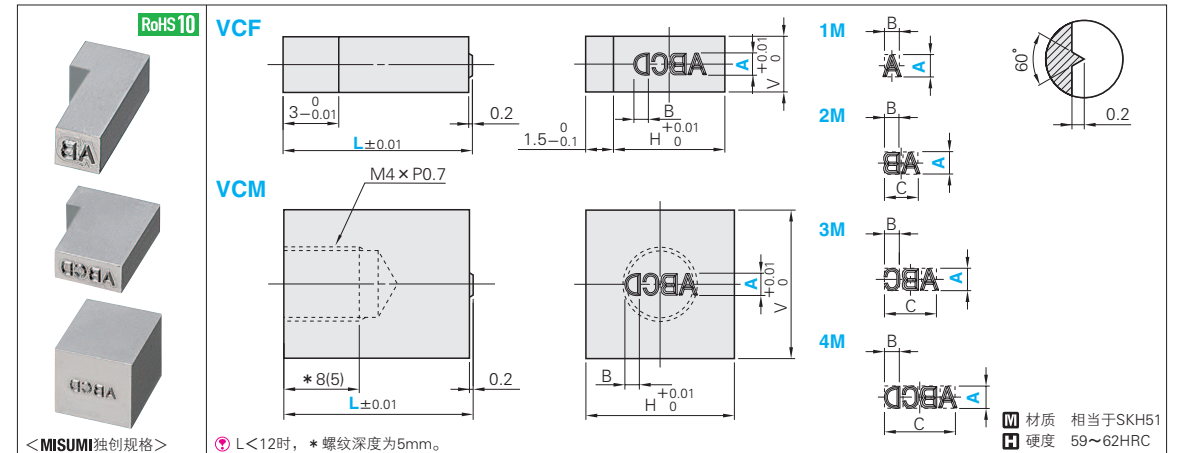
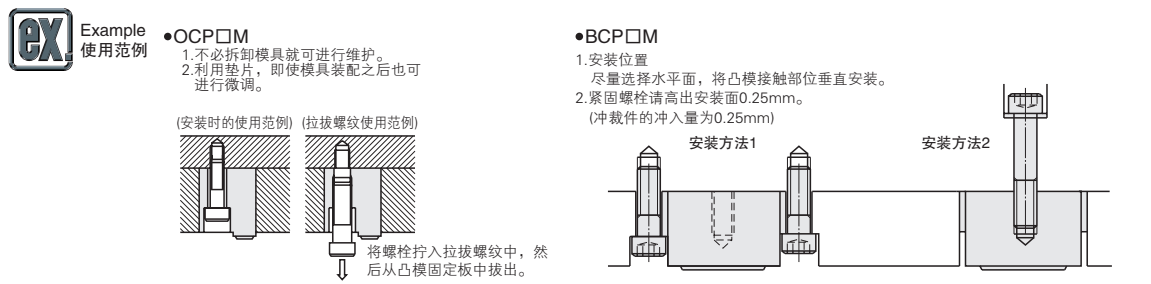

V	H	A	B	C	Catalog No.		A	指定单位0.1mm L	文字(粗体) CHR	
					Type	文字数				
3	2	1.0	0.7	-	VCF	1M	1.0	8.0~30.0	0 1 2 3 4 5 6 7 8 9 A B C D E F G H I J K L M N O P Q R S T U V W X Y Z (注1) [] (空格) (注2) - (连字号)	
		1.2	0.8	-			1.2			
		1.5	1.0	-			1.5			
		1.0	0.7	1.8			1.0			
		1.2	0.8	2.0			1.2			
		1.5	1.0	2.4			1.5			
	3	3	1.0	0.7		3.0	2M			1.0
			1.2	0.8		3.3				1.2
			1.5	1.0		3.9				1.5
			1.0	0.7		4.1				1.0
			1.2	0.8		4.5				1.2
			1.5	1.0		5.3				1.5
8	8	1.0	0.7	-	VCM	1M	1.0			
		1.2	0.8	-			1.2			
		1.5	1.0	-			1.5			
		1.0	0.7	1.8			1.0			
		1.2	0.8	2.0			1.2			
		1.5	1.0	2.4			1.5			
	8	8	1.0	0.7		3.0	2M	1.0		
			1.2	0.8		3.3		1.2		
			1.5	1.0		3.9		1.5		
			1.0	0.7		4.1		1.0		
			1.2	0.8		4.5		1.2		
			1.5	1.0		5.3		1.5		

Order 订货范例 Catalog No. - [A] - [L] - [CHR] 实际的刻印
 VCF3M - 1.5 - 20.0 - ABC
 VCF3M - 1.5 - 25.0 - %AB
 VCM4M - 1.5 - 20.0 - ABCD
 VCM4M - 1.5 - 25.0 - A#B%

Delivery 交货期 9 天发货
 上海·广州发货
 数量≥101时, 请另询交货期。

Alterations 追加加工 Catalog No. - [A] - [L] - [CHR] - (VHM·VHZ...etc.)
 VCM3M - 1.2 - 15.0 - ABC - CCP180

Alterations	Code	Spec.
	VHM	变更杆径 尺寸公差 $V \cdot H_{+0.01} \Rightarrow -0.01$
	VHZ	变更杆径 尺寸公差 $V \cdot H_{+0.01} \Rightarrow \pm 0.005$
	HC	变更凸缘宽度 $0 \leq HC < 1.5$ 指定单位0.1mm VCM不适用
	CCP	杆部1处C倒角(错误防止用) 杆角1处进行C1.0倒角处理。 指定C倒角位置(从刻印面侧看时) CCP0 CCP90 CCP180 CCP270 VCF不适用

刻印方形凸模	字体
OCP□M (P.701) BCP□M (P.701) VCF□M VCM□M	0 1 2 3 4 5 6 7 8 9 A B C D E F G H I J K L M N O P Q R S T U V W X Y Z

精密级刻印方形凸模精度标准

精度标准		
垂直度		$a \leq 0.005$
平行度		$b \leq 0.005$