

MEVWN600 (θ=00-40)

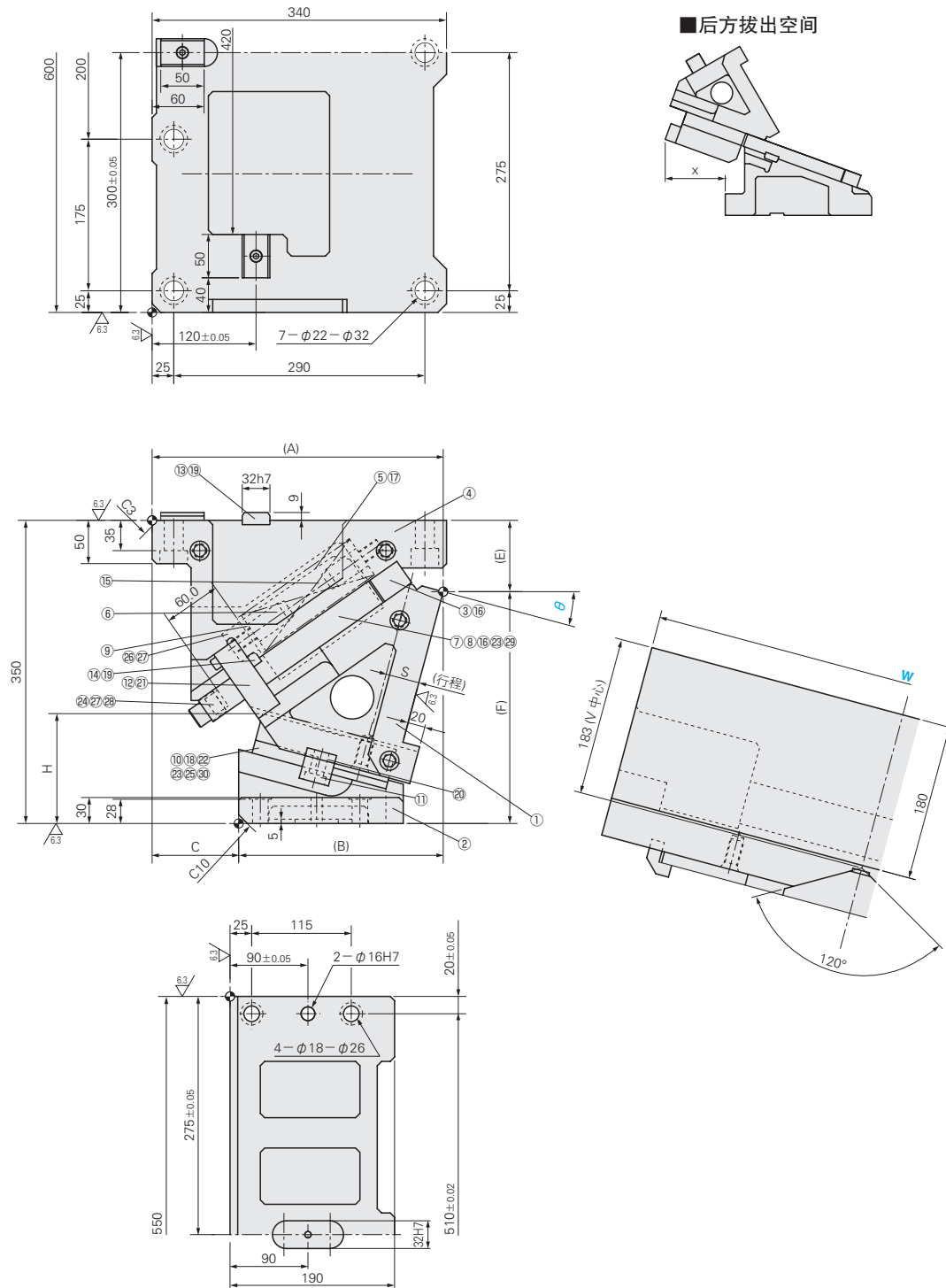

■斜楔行程关系图 P.1247

■构成零件表 P.1249

W	θ	A	B	C	E	F	H	x
600	00	313	175	138	58	292	102	47
	05	320.64	195.64	125	64.34	285.66	110.8	61
	10	331.08	216.08	115	72.47	277.53	119.1	70
	15	336.17	236.17	100	82.37	267.63	126.8	80
	20	340.76	255.76	85	94	256	133.9	88
	30	347.83	292.83	55	112.25	237.75	155.7	103
	40	351.17	326.17	25	136.66	213.34	173.9	116

行程 S	加工力KN (tonf)		弹簧力N (kgf)			总重量 kg	Catalog No.	W	θ	
	标准加工力	极限加工力	初压	下死点前5mm	终压					
38.6	392.3 (40.0)	783.6 (79.9)	3269 (333.3)	17488 (1783.3)	19613 (1999.9)	281.4	MEVWN	600	00	
42.6				17706 (1805.5)					277.9	05
46.7				17869 (1822.2)					274.1	10
50.9				18006 (1836.1)					272.3	15
55.3				18142 (1850.0)					268.8	20
65.1				18360 (1872.2)					276.6	30
77.1				18550 (1891.6)					285.2	40



Order 订货范例

Catalog No. W - θ
MEVWN 600 - 10



Delivery 交货期

请通过 **MISUMI** 询价。
(<https://cn.misumi-ec.com>)



Alterations 追加加工

Catalog No. W - θ - (N · K · FK)
MEVWN 600 - 10 - N

Alterations	Code	Spec.
	N	定位销孔加工 在斜楔底座上加工2处φ16H7定位销孔。
	K	追加定位键 (带1个 M8×15内 六角螺钉)

Alterations	Code	Spec.																	
	FK	移动键位置 将斜楔底座的定位键向前移动。																	
氮气弹簧	GK GD	<table border="1"> <thead> <tr> <th>Code</th> <th colspan="2">弹簧力 (kgf)</th> <th rowspan="2">规格</th> <th rowspan="2">备注</th> </tr> <tr> <th>初压</th> <th>终压</th> </tr> </thead> <tbody> <tr> <td>GK</td> <td>—</td> <td>2730.4</td> <td>K750-064</td> <td>KALLER</td> </tr> <tr> <td>GD</td> <td>—</td> <td>2716.3</td> <td>L750.075</td> <td>DADCO</td> </tr> </tbody> </table>	Code	弹簧力 (kgf)		规格	备注	初压	终压	GK	—	2730.4	K750-064	KALLER	GD	—	2716.3	L750.075	DADCO
		Code	弹簧力 (kgf)		规格			备注											
初压	终压																		
GK	—	2730.4	K750-064	KALLER															
GD	—	2716.3	L750.075	DADCO															