

MEVWN200 (θ=50-60)

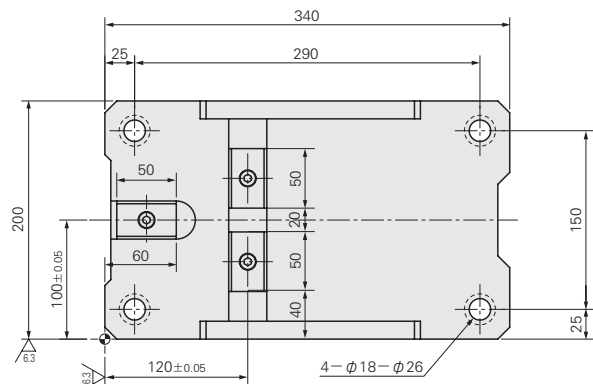

■后方拔出空间

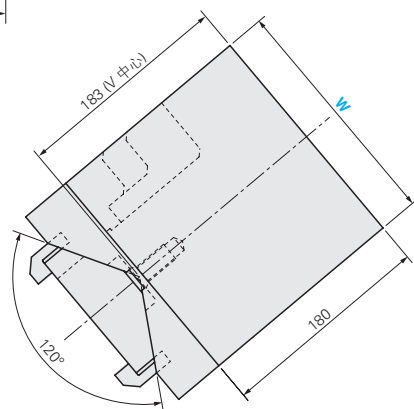
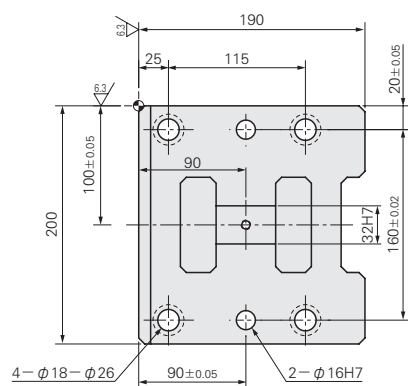
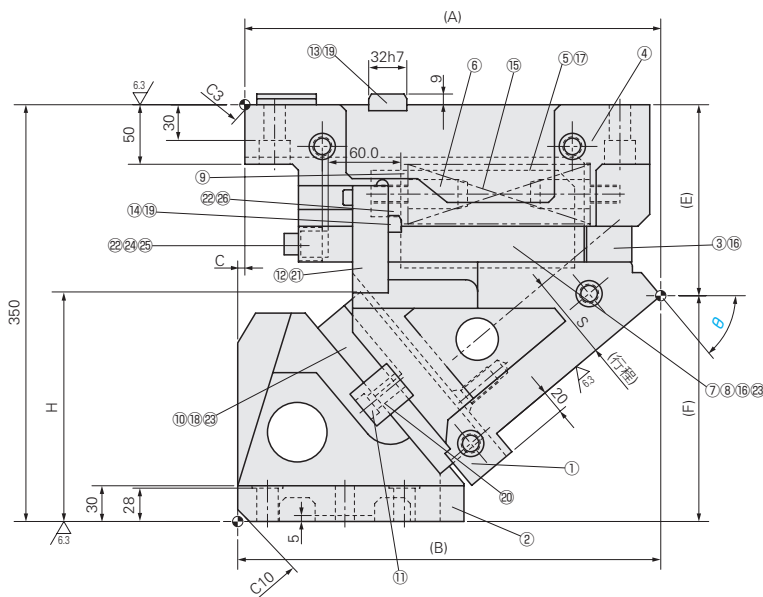
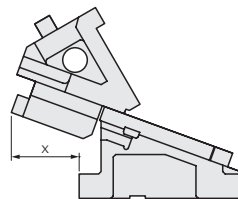

■斜楔行程关系图 P.1247

■构成零件表 P.1249

W	θ	A	B	C	E	F	H	x
200	50	348.77	354.77	6	161.49	188.51	192.8	126
	60	332.75	377.75	45	195.83	154.17	202.1	152

行程 S	加工力KN (tonf)		弹簧力N (kgf)			总重量 kg	Catalog No.	W	θ
	标准加工力	极限加工力	初压	下死点前5mm	终压				
93.3	117.7 (12.0)	235.4 (24.0)	817 (83.3)	4685 (477.8)	4903 (500.0)	93.7	MEVWN	200	50
120.0				4733 (482.6)					60

Order 订货范例 Catalog No. **MEVWN** **200** - **50**

Delivery 交货期 **库存品**
 隔日上海·广州发货 P.41
 数量≥5时, 请另询交货期。

Alterations 追加加工 Catalog No. **MEVWN** **200** - **50** - (N·K·FK) **K**
 请通过 MISUMI 询价 (https://cn.misumi-ec.com)

Alterations	Code	Spec.																	
	N	定位销孔加工 在斜楔底座上加工2处φ16H7定位销孔。																	
	K	追加定位键 (带1个M8×15内六角螺钉) 附属键																	
	FK	移动键位置 将斜楔底座的定位键向前移动。																	
氮气弹簧	GK GD	<table border="1"> <thead> <tr> <th rowspan="2">Code</th> <th colspan="2">弹簧力 (kgf)</th> <th rowspan="2">规格</th> <th rowspan="2">备注</th> </tr> <tr> <th>初压</th> <th>终压</th> </tr> </thead> <tbody> <tr> <td>GK</td> <td>—</td> <td>682.6</td> <td>K750-064</td> <td>KALLER</td> </tr> <tr> <td>GD</td> <td>—</td> <td>679.1</td> <td>L750.075</td> <td>DADCO</td> </tr> </tbody> </table>	Code	弹簧力 (kgf)		规格	备注	初压	终压	GK	—	682.6	K750-064	KALLER	GD	—	679.1	L750.075	DADCO
Code	弹簧力 (kgf)			规格	备注														
	初压	终压																	
GK	—	682.6	K750-064	KALLER															
GD	—	679.1	L750.075	DADCO															