

MEFL50 ($\theta = 00-50$)

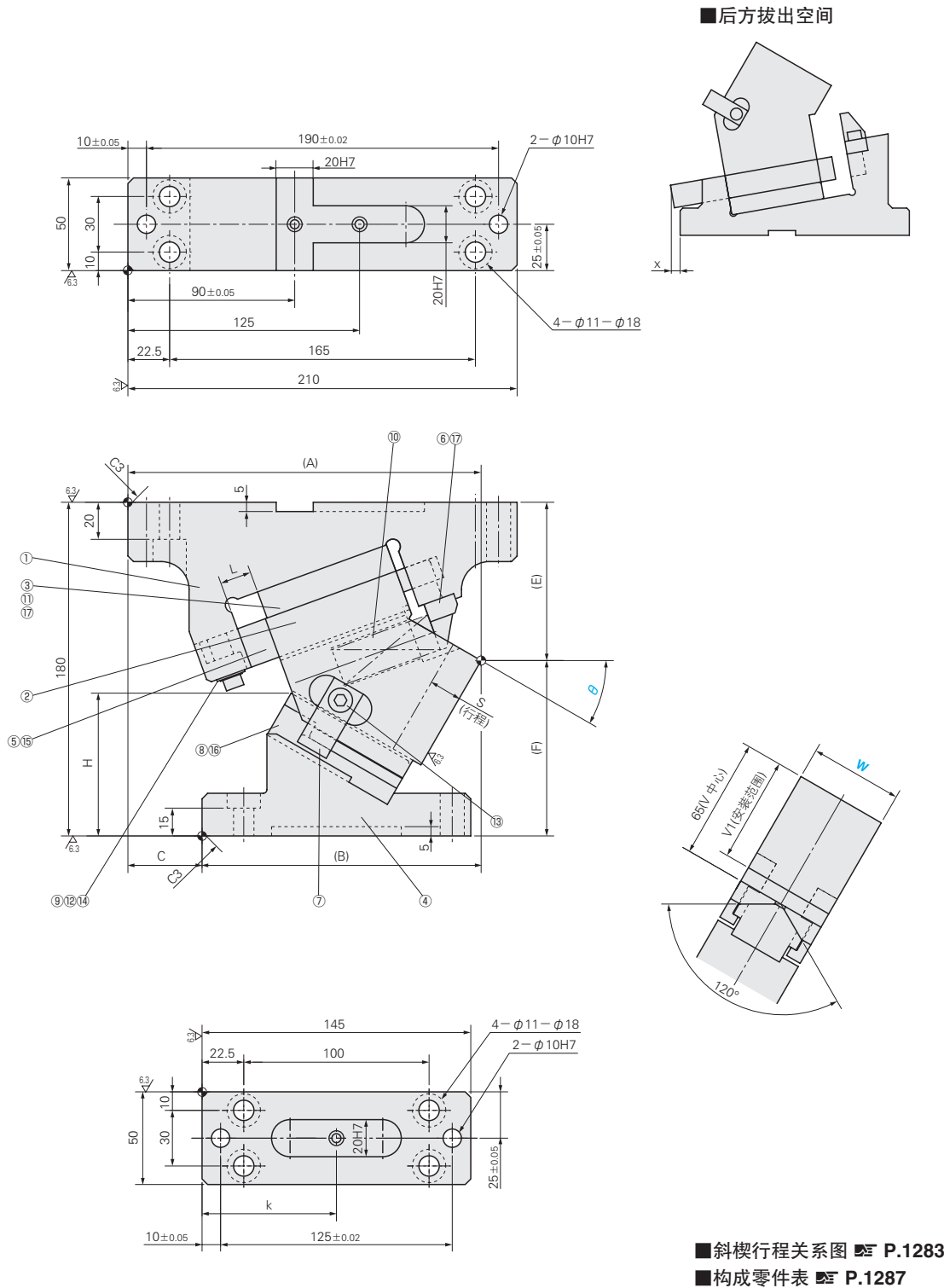

W	θ	A	B	C	E	F	H	L	V ₁	k	x	
50	00	195	115	80	67.5	112.5	46	23.3	65	72.5	0	
	05	198.04	123.04	75	68.29	111.71	52.4	22				
	10	195.99	130.99	65	69.77	110.23	58.6	20				
	15	198.77	133.77		71.95	108.05	64.5					
	20	196.34	141.34	55	74.79	105.21	70.1	16				
	25	191.62	150.62	41	80.28	99.72	73.3					18
	30	190.58	150.58	40	85.39	94.61	77					
	35	187.15	162.15	25	90.1	89.9	81.3					
	40	183.29	160.79	22.5	95.35	84.65	85.1					
	45	179.94	169.94	10	98.13	81.87	91.4	55				
50	174.07	169.07	5	99.37	80.63	99.2	15		72.5			

行程 S	加工力KN (tonf)		弹簧力N (kgf)			总重量 kg	Catalog No.	W	θ
	标准加工力	极限加工力	初压	下死点前5mm	终压				
15.0	29.4 (3.0)	58.8 (6.0)	184(18.8)	792(80.7)	1098(111.9)	10.6	MEFL	50	00
15.6			180(18.3)	853(87.0)	1167(119.0)	10.3			05
15.6			269(27.5)	880(89.7)		9.9			10
17.0				902(92.0)	9.7	15			
18.4			359(36.6)	925(94.3)	9.4	20			
18.0				943(96.1)	9.4	25			
17.4			263(26.8)	863(88.0)	9.2	30			
18.9				884(90.1)	9.2	35			
20.6				899(91.7)	9.1	40			
22.5			316(32.2)	921(93.9)	9.1	45			
23.3	936(95.5)	9.0		50					

Order 订货范例 Catalog No. **MEFL** W **50** - θ **35**

Delivery 交货期 **另** 库存品 **另** 询交货期

Price 价格 询价联系方式: WOS: <https://www.misumi-ec.com/cn/> P.57 TEL: 021-6710-8701 / FAX: 021-6710-8984 P.1663

Alterations 追加加工 Catalog No. **MEFL** W **50** - θ **15** - (N12 · N13...etc.) **另** 询交货期

Alterations	Code	Spec.
$\phi 12H7$ or $\phi 13H7$	N12	变更定位销孔径 $\phi 10H7 \Rightarrow \phi 12H7$
	N13	变更定位销孔径 $\phi 10H7 \Rightarrow \phi 13H7$
	K	追加定位键(3个) (带3个M8×15内六角螺钉) 附属键
	KA	追加台阶型定位键(3个) (带3个M8×15内六角螺钉) 附属键