

MEVHN65 ($\theta=00-55$)

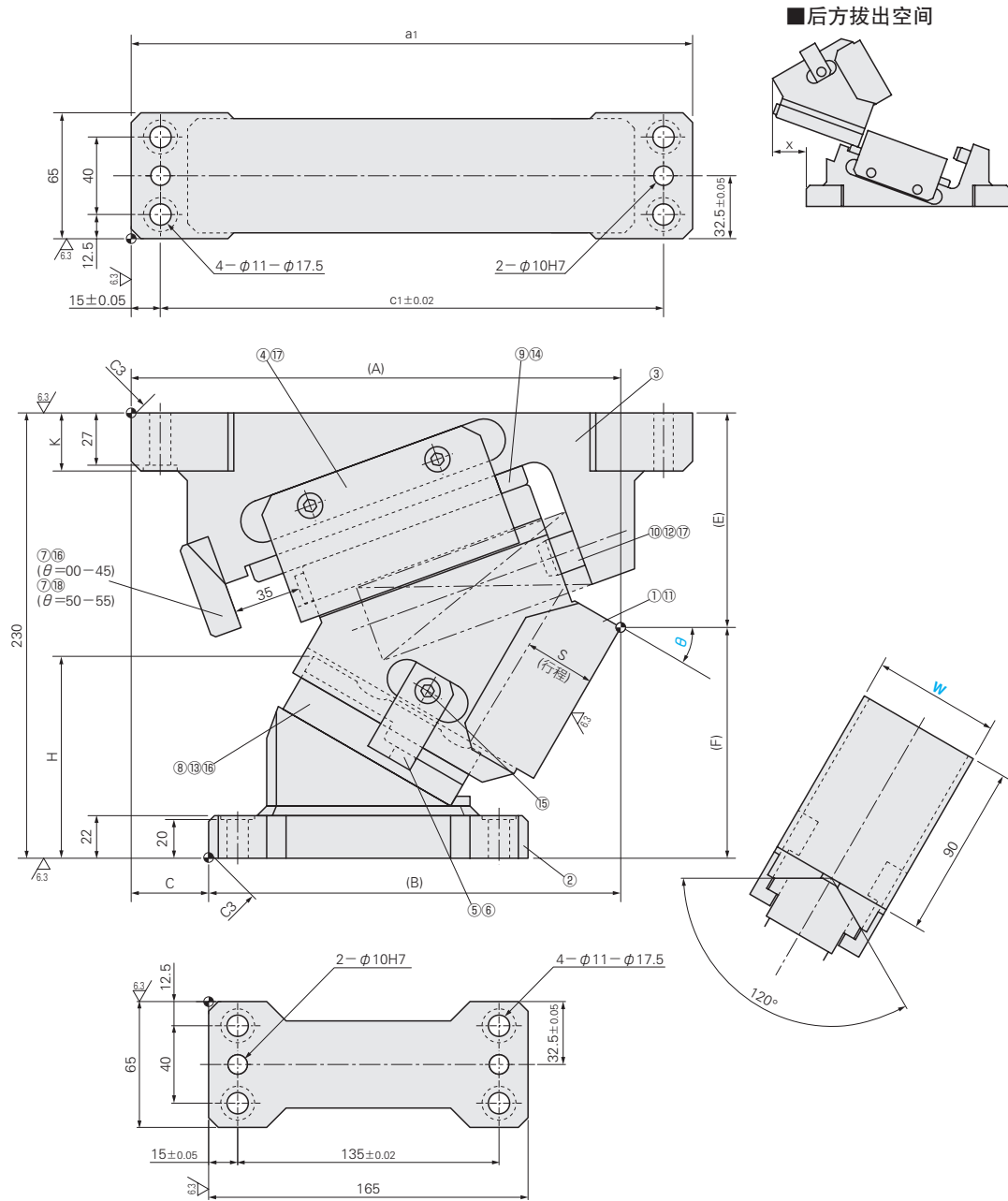

W	θ	A	B	C	E	F	H	K	a1	c1	x
65	00	255	160	95	79.2	150.8	58.5	30	275	245	0
	05	265.68	170.68		82.29	147.71	67.1				
	10	256.04	181.04		86.29	143.71	75.4				
	15	266.02	191.02	91.18	138.82	83.3					
	20	255.53	195.53	96.93	133.07	90.8					
	25	264.51	204.51	103.48	126.52	97.8					
	30	252.88	212.88	110.79	119.21	104.3					
	35	260.58	220.58	118.8	111.2	110.2					
	40	242.56	222.56	122.45	107.55	120.4					
	45	248.75	228.75	131.67	98.33	125					
	50	236.28	236.28	125.98	104.02	148.1					
	55	240.78	240.78	136.14	93.86	153.1					

行程 S	加工力KN (tonf)		弹簧力N (kgf)			总重量 kg	Catalog No.	W	θ
	标准加工力	极限加工力	初压	下死点前5mm	终压				
22.5	68.6 (7.0)	137.3 (14.0)	0 (0.0)	4654(474.6)	5989 (610.7)	18.4	MEVHN	65	00
22.6				4671(476.3)		18.6			05
27.2				4893(499.0)		17.4			10
27.8				4911(500.7)		17.5			15
32.3				5065(516.4)		16.6			20
33.4				5099(519.9)		16.8			25
38.0				5201(530.4)		16.9			30
40.2				5236(533.9)		17.0			35
45.0				5321(542.6)		16.4			40
48.7				5373(547.8)		16.6			45
54.5				5441(554.8)		15.9			50
61.0				5492(560.1)		16.1			55



Order 订货范例

Catalog No. **MEVHN** W **65** - θ **10**



Delivery 交货期

• 红字规格
 库存品
 隔日上海·广州发货 P.41
 数量 ≥ 5 时, 请另询交货期。

• 左述以外

另 询交货期



Price 价格

询价联系方式:
 WOS: <https://www.misumi-ec.com/cn/> P.57
 TEL: 021-6710-8701 / FAX: 021-6710-8984 P.1663