

# シヨルダーボルト 带肩螺栓

# エジェクタプレートセット用ボルト 推板安装用螺栓

ネジ・ワッシャ  
小物

螺栓・垫圈  
小零件

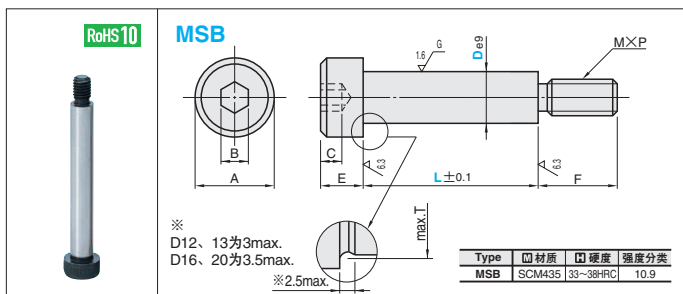

De9	A	B	C	E	F	M×P	T
4	6.5	2.5	1.6	3	5	2.5×0.45	4.5
4.5	7				6	3×0.5	5
5	8			3.5	6		5.5
5.5	9	3	2.2	4	7	4×0.7	6
6			2				6.5
6.5	10	4	2.5	5	9	5×0.8	7
8	13	5	3	6		6×1.0	8.7
10	16	6	4	8	12	8×1.25	10.8
12	17						12.8
13	18	8	5	10	16	10×1.5	14
16	24	10	7	14	18	12×1.75	17
20	27	14	9	18	24	16×2.0	21

Type	D	L																													
		4	5	6	8	10	12	15	20	25	30	35	40	45	50	55	60	65	70	75	80	85	90	95	100	110	120	130	140	150	
MSB	4	10	15	20	25	30	35	40	45																						
	4.5	10	15	20	25	30	35	40	45	50																					
	5	10	15	20	25	30	35	40	45	50																					
	5.5	10	15	20	25	30	35	40	45	50	55																				
	6	10	15	20	25	30	35	40	45	50	55	60	65	70																	
	6.5	10	15	20	25	30	35	40	45	50	55	60	65	70	75	80															
	8	10	15	20	25	30	35	40	45	50	55	60	65	70	75	80	85	90	95	100	110	120									
	10	10	15	20	25	30	35	40	45	50	55	60	65	70	75	80	85	90	95	100	110	120	130								
	12	10	15	20	25	30	35	40	45	50	55	60	65	70	75	80	85	90	95	100											
	13	10	15	20	25	30	35	40	45	50	55	60	65	70	75	80	85	90	95	100	110	120	130								
16		15	20	25	30	35	40	45	50	55	60	65	70	75	80	85	90	95	100	110	120	130	140	150							
20							40	50	60	70	80	90	100	110	120	130	140	150													

Order 订货范例: 型号 MSB 10 - L 50

Alterations 追加加工: 型号 MSB 10 - L(LC) - (FC) 11 天发货

Delivery 交货期: 隔日上海·广州发货 P.41 (17:00前订购的库存品可当日发货。)

库存品: 数量 > 51时, 请另询交货期。

Alterations	Code	Spec.
	LC	变更L尺寸(切削加工) 全长(LC)公差变为±0.05。 Lmin. < LC < Lmax. 指定单位0.1mm F尺寸按照规格尺寸制作。 需要变更F尺寸时, 请与FC并用。
	FC	变更螺纹部长度 M < FC < M×3 指定单位0.5mm 仅D=4时, 3 < FC < 7.5 仅与LC并用时适用。

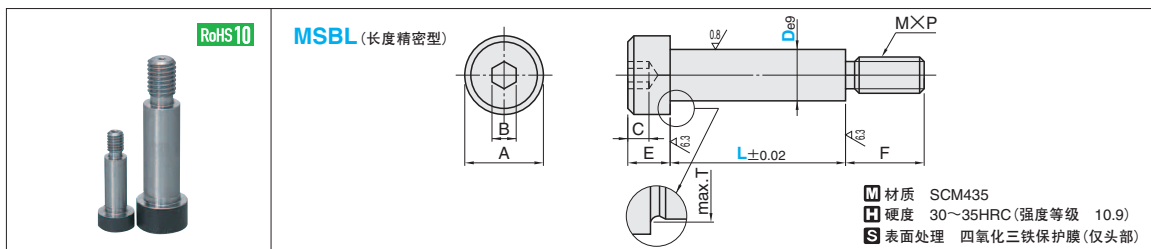

De9	A	B	C	E	F	M×P	T	L																						
								Type	D	4	5	6	8	10	12	15	20	25	30	35	40	45	50							
MSBL	6.5	10	4	2.5	5	9	5×0.8	7	6.5	10	15	20	25	30	40															
	8	13	5	3	6	9	6×1.0	8.7	8	10	15	20	25	30	35	40	45													
	10	16	6	4	8	12	8×1.25	10.8	10	15	20	25	30	35	40	45	50													
	13	18	8	5	10	16	10×1.5	14	13	15	20	25	30	35	45	50														
16	24	10	7	14	18	12×1.75	17	16		20	25	30																		
20	27	14	9	18	24	16×2.0	21	20		20	25	30																		

Order 订货范例: 型号 MSBL 10 - L 50

Delivery 交货期: 隔日上海·广州发货 P.41 (17:00前订购的库存品可当日发货。)

库存品: 数量 > 501时, 请另询交货期。

Example 使用范例: 右页

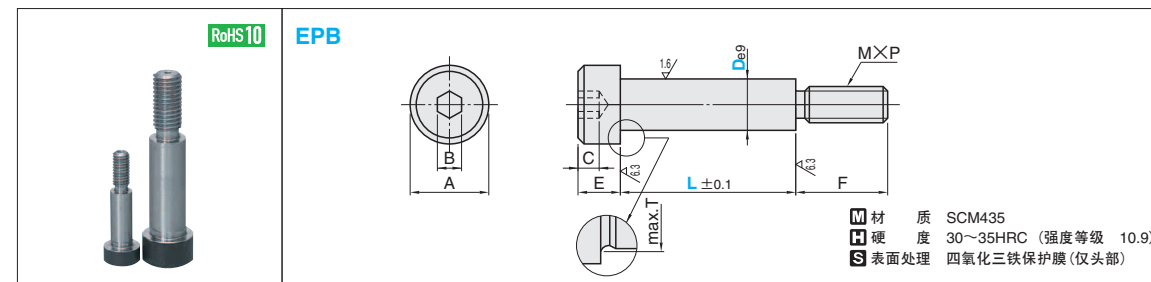

De9	A	B	C	E	F	M×P	T	L																							
								Type	D	10	13	16	20	25	31	36	41	46	51	56	61	66	71	76	81	91	101	111	121	131	141
EPB	10	16	6	4	8	16	8×1.25	10.8	10	13	16	20	25	31	36	41	46	51	56	61											
	13	18	8	5	10	20	10×1.5	14	13	16	20	25	31	36	41	46	51	56	61	66	71										
	16	24	10	7	14	24	12×1.75	17	16		51	56	61	66	71	76	81	91	101	111	121	131									
	20	27	14	9	18	32	16×2.0	21	20		61	66	71	76	81	91	101	111	121	131	141										
	25	33	17	11	19	40	20×2.5	26	25																						

Order 订货范例: 型号 EPB 10 - L 51

Delivery 交货期: 隔日上海·广州发货 P.41 (17:00前订购的库存品可当日发货。)

库存品: 数量 > 201时, 请另询交货期。

Example 使用范例: 安装或更换推杆等场合, 需提升并固定推板时, 请使用此螺栓。配合5mm倍数的空间间隔, L尺寸为5mm指定单位+1mm。因此, 推板上侧无需加工沉孔, 即可将模具装到注塑机上。因螺纹部(F尺寸)较长, 故便于安装推板, 而不必承受弹簧的负载。

D	M×P	F(螺纹长度)	
		MSB·MSBL	EPB
10	8×1.25	12	16
13	10×1.5	16	20
16	12×1.75	18	24
20	16×2.0	24	32
25	20×2.5	-	40

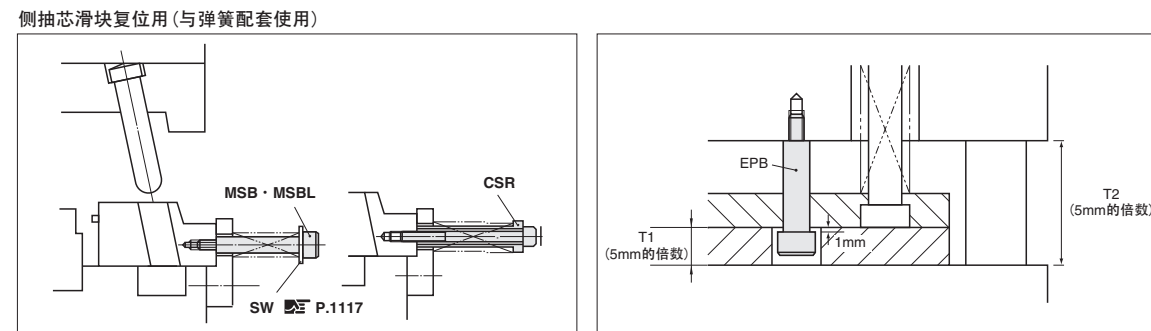

- 弹簧: P.1133~
- 侧抽芯滑块挡块: P.615
- 斜导柱: P.577