

型芯用硬化板

-上、下2面研磨型/6面研磨型-

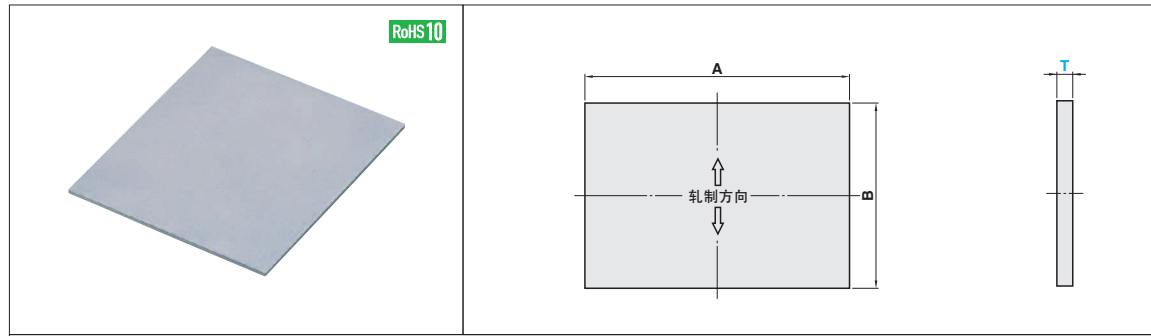

■上、下2面研磨型

型号	材质	硬度	厚度公差	A·B·T的表面粗糙度	精度基准
HPSHW	SKH51	57~63HRC	T $\begin{matrix} +0.05 \\ +0.03 \end{matrix}$	上下研磨面的表面粗糙度 $\sqrt{1.5}^G$ ④4条侧边有时会留有切断痕迹。	上下面的平行度 0.02/100mm以下
HPHEW	SKH51	57~63HRC	No. 0.5~0.8 T $\begin{matrix} +0.05 \\ +0.02 \end{matrix}$ No. 1~10 T $\begin{matrix} +0.3 \\ +0.1 \end{matrix}$		上下面的平行度 T ≤ 1.5时: 0.2/100mm以下 T ≥ 2.0时: 0.1/100mm以下
HPSWW	SKH51	57~63HRC	T $\begin{matrix} +0.05 \\ +0.03 \end{matrix}$		上下面的平行度 0.1/100mm以下

■6面研磨型

型号	材质	硬度	厚度公差	A·B·T表面粗糙度	精度基准
HPSH	SKH51	57~63HRC	T $\begin{matrix} +0.05 \\ +0.03 \end{matrix}$	A·B·T表面粗糙度 $\sqrt{1.5}^G$	A·B面垂直度 0.02/100mm以下 上下面平行度 0.02/100mm以下
HPHE	SKH51	57~63HRC	T ≤ 0.8时: T $\begin{matrix} +0.05 \\ +0.02 \end{matrix}$	A·B·T表面粗糙度 $\sqrt{1.5}^G$	A·B面垂直度 0.05/100mm以下 上下面平行度 T ≤ 1.5时: 0.2/100mm以下 T ≥ 2.0时: 0.1/100mm以下
HPDE	SKD61	50~53HRC	T ≥ 1.0时: T $\begin{matrix} +0.3 \\ +0.1 \end{matrix}$		



Order 订货范例
型号
HPSHW 1
HPSH 1.8



Delivery 交货期
库存品
隔日上海·广州发货 P.41
(17:00前订购的库存品可当日发货。)
数量 > 51时, 请另询交货期。



Alterations 追加加工
型号 - (TC)
HPSHW 1 - TC-0.95

Alteration	Code	Spec.
	TC	变更板厚
		指定方法 TC-0.95
		指定单位 0.01mm
		④仅适用于HPSHW(No.0.8~4)
		No. Tmin.~Tmax.
		0.8 0.70~0.79
		0.9 0.80~0.89
1 0.90~0.99		
1.3 1.00~1.29		
1.5 1.30~1.49		
1.8 1.50~1.79		



Example 使用范例
•连接器、开关等方孔用模具型芯材料
•扁推杆材料等
(1)加工方法
•线切割加工

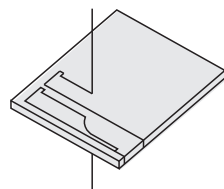

•形状加工后切断

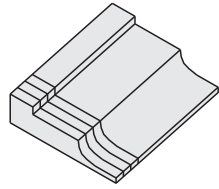

(2)型芯使用范例

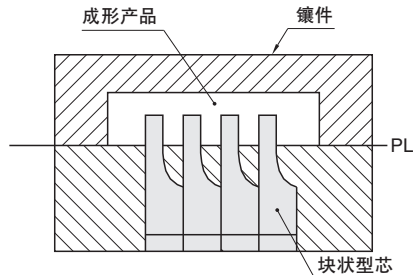

■上、下2面研磨型

A		B		T		型号	
						Type	No.
60	+5 +0.1	50	+5 +0.1	0.8	+0.05 +0.03	HPSHW (SKH51)	0.8
				0.9			0.9
				1			1
				1.3			1.3
				1.5			1.5
				1.8			1.8
				2			2
				2.5			2.5
				3			3
				3.5			3.5
100	+5 +0.1	60	+5 +0.1	4	+0.05 +0.03	HPSHW (SKH51)	4
				4.5			4.5
				5			5
				5.5			5.5
				6			6
				8			8
				10			10

A		B		T		型号	
						Type	No.
80	+5 +0.1	70	+5 +0.1	0.5	+0.05 +0.02	HPHEW (SKH51)	0.5
				0.6			0.6
				0.8			0.8
				1			1
				1.5			1.5
				2			2
150	+5 +0.1	60	+5 +0.1	3	+0.3 +0.1	HPHEW (SKH51)	3
				4			4
				5			5
				6			6
				8			8
				10			10

A		B		T		型号	
						Type	No.
200	+5 +0.1	100	+5 +0.1	1	+0.05 +0.03	HPSWW (SKH51)	1
				1.5			1.5
				2			2
				2.5			2.5
3	3						

■6面研磨型

A		B		T		型号	
						Type	No.
80	+0.3 +0.1	70	+0.3 +0.1	1	+0.05 +0.03	HPSH (SKH51)	1
				1.3			1.3
				1.5			1.5
				1.8			1.8
				2			2
				3			3
100	+0.3 +0.1	80	+0.3 +0.1	4	+0.05 +0.03	HPSH (SKH51)	4
				5			5
				6			6

A		B		T		型号	
						Type	No.
80	+1.0 0	70	+1.0 0	0.5	+0.05 +0.02	HPHE (SKH51)	0.5
				0.6			0.6
				0.8			0.8
150	+1.0 0	60	+1.0 0	1	+0.3 +0.1	HPHE (SKH51)	1
				1.5			1.5
				2			2
				3			3
				4			4
				5			5
150	+1.0 0	60	+1.0 0	6	+0.3 +0.1	HPDE (SKD61)	6
				1			1
				1.5			1.5
				2			2
				3			3
				4			4