

H	D	型号		指定单位0.01mm	
		Type	P	L	S
3	1	EPSH (P ⁰ _{-0.005}) EPSHE (P ^{-0.01} _{-0.02})	1	5.00~150.00	5.00~40.00
	1.5		1.5		
4	2				
5	2.5				
6	3		3	5.00~200.00	
7	3.5		3.5		
8	4.5		4.5	5.00~250.00	5.00~50.00
9	5.5		5.5		
10	6		6		
	6.5		6.5		
	7	7			

Order 订货范例
 型号 L S
 EPSH 5 - 60.00 - S10.00

Delivery 交货期
 3 天发货
 上海·广州发货
 数量>51时, 请另询交货期。

Alterations 追加加工
 型号 L S (HC·TC...etc.)
 EPSH 5 - 60.00 - S10.00 - TC3.0

追加加工详情 P.240

Alterations	Code	Spec.	Alterations	Code	Spec.
	KC	KC尺寸指定单位0.1mm D/2+0.1 < KC < H/2		SKC	SKC尺寸指定单位0.1mm D/2+0.1 < SKC < H/2
	WKC	WKC尺寸指定单位0.1mm D/2+0.1 < WKC < H/2		KGC	KGC尺寸指定单位0.1mm AG角度指定单位1° D/2+0.1 < KGC < H/2且0 < AG < 360
	KAC KBC	KAC, KBC尺寸指定单位0.1mm D/2+0.1 < KAC < KBC < H/2		KTC	KTC尺寸指定单位0.1mm D/2+0.1 < KTC < H/2
	RKC	RKC尺寸指定单位0.1mm D/2+0.1 < RKC < H/2		HC	HC尺寸指定单位0.1mm P+1 < HC < H
	DKC	DKC尺寸指定单位0.1mm D/2+0.1 < DKC < H/2		TC	TC尺寸指定单位0.1mm 2.0 < TC < 4 (L, S为指定尺寸)



图1·合模时 图2·开模中 图3·开模时

- 中肩直推杆可实现按时间差的顺序顶出动作。
- 顶出时间由沉头孔深度Z(图1中)决定。
- 主要适用于成形产品的脱模及2次顶出场合。

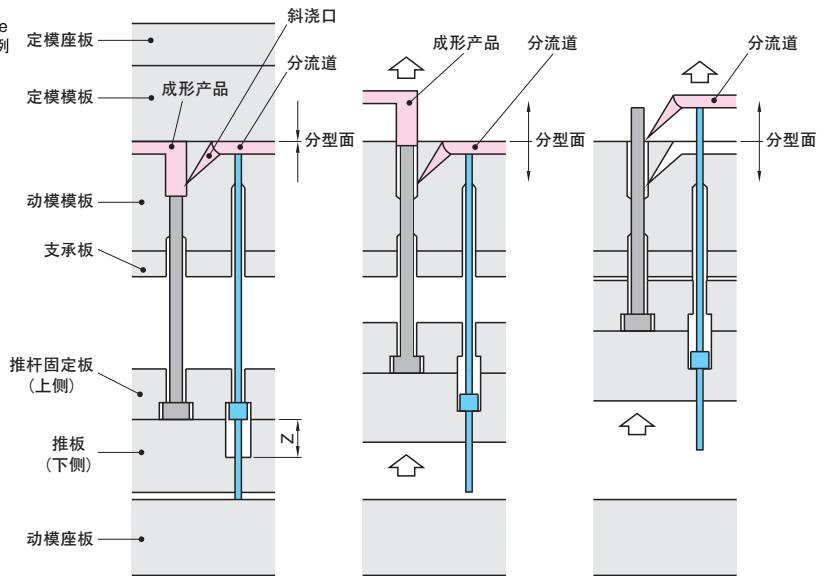