

1.各部位的尺寸

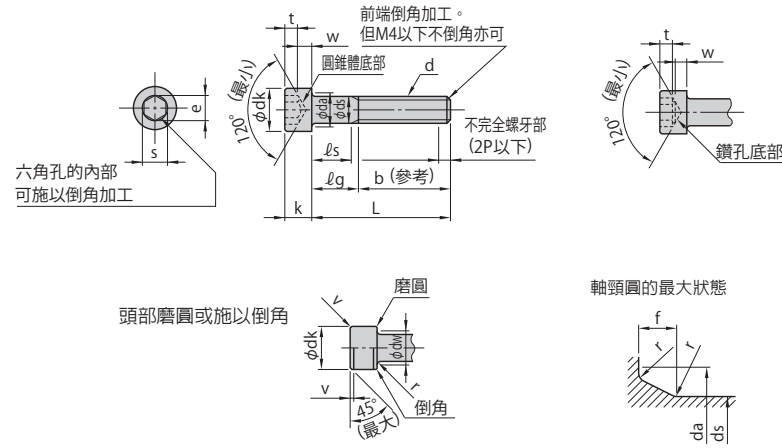

f(最大) = 1.7r(最大)  
 $r(最大) = \frac{da(最大) - ds(最大)}{2}$   
 r(最小) = 依下表中之值

單位：mm

螺牙No.(d) <sup>(?)</sup>	M2	M2.5	M3	M4	M5	M6	M8	M10	M12	(M14)	M16	(M18)	M20	(M22)	M24	(M27)	M30	
螺牙的間距(P)	0.4	0.45	0.5	0.7	0.8	1	1.25	1.5	1.75	2	2	2.5	2.5	2.5	3	3	3.5	
b 參考	16	17	18	20	22	24	28	32	36	40	44	48	52	56	60	66	72	
dk	最大(標準尺寸)*	3.8	4.5	5.5	7	8.5	10	13	16	18	21	24	27	30	33	36	40	45
	最大**	3.98	4.68	5.68	7.22	8.72	10.22	13.27	16.27	18.27	21.33	24.33	27.33	30.33	33.39	36.39	40.39	45.39
da	最大	3.62	4.32	5.32	6.78	8.28	9.78	12.73	15.73	17.73	20.67	23.67	26.67	29.67	32.61	35.61	39.61	44.61
	最小	2.6	3.1	3.6	4.7	5.7	6.8	9.2	11.2	13.7	15.7	17.7	20.2	22.4	24.4	26.4	30.4	33.4
ds	最大(標準尺寸)	2	2.5	3	4	5	6	8	10	12	14	16	18	20	22	24	27	30
	最小	1.86	2.36	2.86	3.82	4.82	5.82	7.78	9.78	11.73	13.73	15.73	17.73	19.67	21.67	23.67	26.67	29.67
e 最小	1.73	2.30	2.87	3.44	4.58	5.72	6.86	9.15	11.43	13.72	16.00	16.00	19.44	19.44	21.73	21.73	25.15	
f 最大	0.51	0.51	0.51	0.60	0.60	0.68	1.02	1.02	1.45	1.45	1.45	1.87	2.04	2.04	2.04	2.89	2.89	
k	最大(標準尺寸)	2	2.5	3	4	5	6	8	10	12	14	16	18	20	22	24	27	30
	最小	1.86	2.36	2.86	3.82	4.82	5.70	7.64	9.64	11.57	13.57	15.57	17.57	19.48	21.48	23.48	26.48	29.48
r 最小	0.1	0.1	0.1	0.2	0.2	0.25	0.4	0.4	0.6	0.6	0.6	0.6	0.8	0.8	0.8	1	1	
s	No.(標準尺寸)	1.5	2	2.5	3	4	5	6	8	10	12	14	14	17	17	19	19	22
	最大(1)欄	1.560	2.060	2.580	3.080	4.095	5.140	6.140	8.175	10.175	12.212	14.212	14.212	17.230	17.230	19.275	19.275	22.275
t	最小	1	1.1	1.3	2	2.5	3	4	5	6	7	8	9	10	11	12	13.5	15.5
	最大	0.2	0.25	0.3	0.4	0.5	0.6	0.8	1	1.2	1.4	1.6	1.8	2	2.2	2.4	2.7	3
dw 最小	3.40	4.18	5.07	6.53	8.03	9.38	12.33	15.33	17.23	20.17	23.17	25.87	28.87	31.81	34.81	38.61	43.61	
w 最小	0.55	0.85	1.15	1.4	1.9	2.3	3.3	4	4.8	5.8	6.8	7.7	8.6	9.5	10.4	12.1	13.1	

註(1)：s(最大值)的第1欄適用在強度區分為8.8和10.9和性狀區分為A 2-50和A 2-70的螺栓上。s(最大值)的第2欄適用在強度區分為12.9的螺栓上，只要買方和生產者之間的協議一致，第一欄也可適用於強度區分為12.9的螺栓。  
 此外，螺牙No. M20以上的s(最大值)可使用在所有強度區分和性狀區分之螺栓。

註(2)：螺牙No.有括弧者請盡量避免使用。

備註：1. 頭部的側面將會附上平行或交叉的壓紋(參照JIS B 0951壓紋樣式)，此時，dk(最大)是表中有\* 符號之值。

另外，需要無壓紋的螺栓時，由訂購者指定。但dk(最大)將是表中有\* 符號之值。

2. 螺牙No.之建議長度No.(L)將在粗線範圍內。

此外，比虛線位置短的螺栓為全螺牙，軸頭部之不完全螺牙部長度約為3P。

3. 長度No. (L)對比虛線位置長的螺栓之lg(最大)及ls(最小)可利用下述公式求得

$lg(最大) = No.長度(L) - b$   
 $ls(最小) = lg(最大) - 5P$

2.內六角螺栓之L、ls及lg

單位：mm

螺牙No.(d)	L		M2		M2.5		M3		M4		M5		M6		M8		M10		M12		M14		M16		(M18)		M20		(M22)		M24		(M27)		M30					
	min	max	ls min	lg max	ls min	lg max	ls min	lg max	ls min	lg max	ls min	lg max	ls min	lg max	ls min	lg max	ls min	lg max	ls min	lg max	ls min	lg max	ls min	lg max	ls min	lg max	ls min	lg max	ls min	lg max	ls min	lg max	ls min	lg max	ls min	lg max				
5	4.76	5.24																																						
6	5.76	6.24																																						
8	7.71	8.29																																						
10	9.71	10.29																																						
12	11.65	12.35																																						
16	15.65	16.35																																						
20	19.58	20.42	2	4																																				
25	24.58	25.42			5.75	8	4.5	7																																
30	29.58	30.42					9.5	12	6.5	10	4	8																												
35	34.5	35.5							11.5	15	9	13	6	11																										
40	39.5	40.5							16.5	20	14	18	11	16	5.75	12																								
45	44.5	45.5									19	23	16	21	10.75	17	5.5	13																						
50	49.5	50.5									24	28	21	26	15.75	22	10.5	18																						
55	54.4	55.6											26	31	20.75	27	15.5	23	10.25	19																				
60	59.4	60.6											31	36	25.75	32	20.5	28	15.25	24	10	20																		
65	64.4	65.6													30.75	37	25.5	33	20.25	29	15	25	11	21	4.5	17														
70	69.4	70.6													35.75	42	30.5	38	25.25	34	20	30	16	26	9.5	22														
80	79.4	80.6													45.75	52	40.5	48	35.25	44	30	40	26	36	19.5	32	15.5	28	11.5	24										
90	89.3	90.7															50.5	58	45.25	54	40	50	36	46	29.5	42	25.5	38	21.5	34	15	30	9	24						
100	99.3	100.7															60.5	68	55.25	64	50	60	46	56	39.5	52	35.5	48	31.5	44	25	40	19	34						
110	109.3	110.7																	66.25	74	60	70	56	66	49.5	62	45.5	58	41.5	54	35	50	29	44	20.5	38				
120	119.3	120.7																	75.25	84	70	80	66	76	59.5	72	55.5	68	51.5	64	45	60	39	54	30.5	48				
130	129.2	130.8																			80	90	76	86	69.5	82	65.5	78	61.5	74	55	70	49	64	40.5	58				
140	139.2	140.8																			90	100	86	96	79.5	92	75.5	88	71.5	84	65	80	59	74	50.5	68				
150	149.2	150.8																			106	106	106	106	89.5	102	85.5	98	81.5	94	75	90	69	84	60.5	78				
160	159.2	160.8																			106	116	106	116	99.5	112	95.5	108	91.5	104	85	100	79	94	70.5	88				
180	179.2	180.8																							119.5	132	115.5	128	111.5	124	105	120	99	114	90.5	108				
200	199.05	200.95																								135.5	148	131.5	144	125	140	119	134	110.5	128					
220	219.05	220.95																																						
240	239.05	240.95																																						
260	258.95	261.05																																						
280	278.95	281.05																																						
300	298.95	301.05																																						

參考：內六角螺栓之沉頭孔和螺絲孔的尺寸

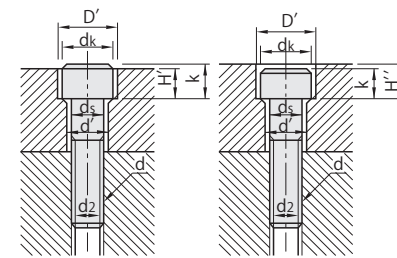

單位：mm

螺牙No.(d)	M3	M4	M5	M6	M8	M10	M12	M14	M16	M18	M20	M22	M24	M27	M30
ds	3	4	5	6	8	10	12	14	16	18	20	22	24	27	30
d	3.4	4.5	5.5	6.6											