

URETHANE SHEETS WITH METAL PLATE 優力膠板金屬板熔接型

優力膠金屬板熔接型可於短交期內供貨。

非型錄規格商品請參照 P.131

CAD資料夾名稱: 38_Urethanes

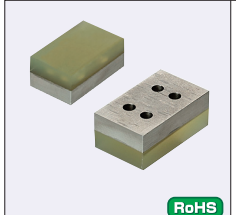

類型	Type	材質	硬度	顏色
A・B尺寸選擇型	UTPFS	醃系優力膠	蕭氏硬度A95	原色
	UTPFH		蕭氏硬度A90	
	UTPFM		蕭氏硬度A70	
	UTPFL		蕭氏硬度A50	
A尺寸自由指定型	UTPFA	醃系優力膠	蕭氏硬度A95	原色
	UTPFAH		蕭氏硬度A90	
	UTPFMA		蕭氏硬度A70	
	UTPFLA		蕭氏硬度A50	

特性 P.417
M板: SUS304

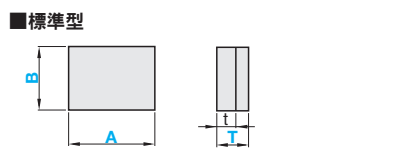

標準型

精密度基準

T公差	公差
10, 15	±0.2

A・B公差

A・B	公差
50以下	±0.3
51~100	±0.5

加工範圍
(攻牙孔間、孔與端面的壁厚)
請設定為b≥2。

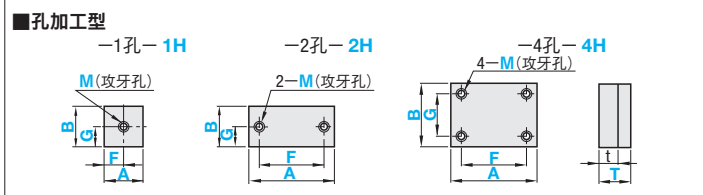

型式		A		B		板孔位置 指定單位0.5mm		攻牙孔 M	t (金屬板厚度)
Type	No.	A・B尺寸選擇型	A尺寸自由指定型 指定單位1mm	選擇		F	G		
A・B尺寸選擇	A尺寸自由指定	10	10~100	10		5~80	4~42	3 4 5 6 8 10	6
UTPFS UTPFH UTPFM UTPFL	UTPFA UTPFAH UTPFMA UTPFLA	20 50 100		20 30 50					10

Order 訂購範例: 型式 - A - B - T - F - G - M

Delivery 出貨日: WEB WOS

Price 價格: WEB WOS

A・B尺寸選擇型

型式	Type	T	NTS基準單價			
			A			
UTPFS UTPFH UTPFM UTPFL	10	10				
		20				
		30				
		50				
		15				
	15	10				
		20				
		30				
		50				

A尺寸自由指定型

型式	Type	T	NTS基準單價			
			A			
UTPFA UTPFAH UTPFMA UTPFLA	10	10				
		20				
		30				
		50				
		15				
	15	10				
		20				
		30				
		50				

攻牙孔加工費用

附孔加工 Type	攻牙孔 M
1H	
2H	
4H	

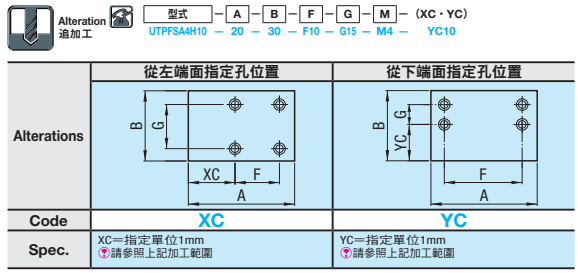

URETHANE BLOCKS-RUBBER BLOCKS 優力膠・橡膠塊

非型錄規格商品請參照 P.131

CAD資料夾名稱: 38_Urethanes

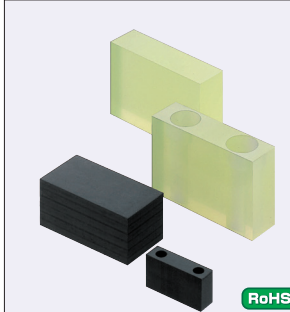

Type	材質	硬度	顏色
BUTSN	醃系優力膠	蕭氏硬度A95	原色
BUTHN		蕭氏硬度A90	原色
BUTM	醃系優力膠	蕭氏硬度A70	原色
BUTL		蕭氏硬度A50	原色
BRBNM	NBR合成橡膠	蕭氏硬度A70	黑
BRBCM	CR合成橡膠	蕭氏硬度A65	黑
BRBFM	氟素橡膠	蕭氏硬度A80	黑
BRBSM	矽膠	蕭氏硬度A70	淺灰
BRBAM	矽膠	蕭氏硬度A50	乳白
BUNSE	低彈性橡膠	蕭氏硬度A32	黑

特性 P.417

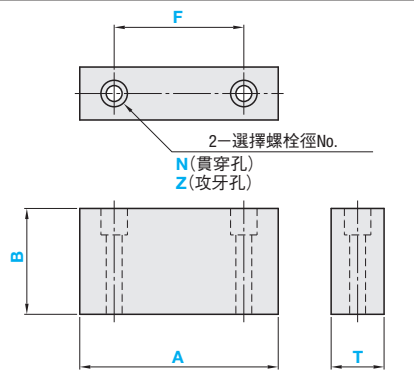

Type	材質	公差		
BUTSN	醃系優力膠	T尺寸公差	6~9	10以上
BUTHN		±0.3	±0.5	
BUTM	醃系優力膠	A・B尺寸公差	30mm以下	31~50
BUTL		±0.5	±0.7	±0.8
BRBNM	NBR合成橡膠	T尺寸公差	6~9	10以上
BRBCM	CR合成橡膠	±0.5	±0.8	
BRBFM	氟素橡膠	A・B尺寸公差	30mm以下	31~50
BRBSM	矽膠	±0.8	±1.0	±1.5
BRBAM	矽膠			
BUNSE	低彈性橡膠			

孔加工詳細尺寸

選擇螺絲徑No.	3	4	5	6	8	10	12
d	3.5	4.5	5.5	6.5	9	12	14
di	6.5	8	9.5	11	14	17.5	20.5
h	3.5	4.5	5.5	6.5	9	11	14

型式	指定單位1mm				選擇螺絲徑No.											
	A	B	T	F	N (貫穿孔)・Z (沉頭孔)											
BUTSN (優力膠A95)	25~150	25~100	6~30	9~141	0 3 4 5 6 8 10 12 (B<30時)											
BUTHN (優力膠A90)					0 5 6 8 10 12 (30≤B<50時)											
BUTM (優力膠A70)					0 8 10 12 (50≤B時)											
BUTL (優力膠A50)					0 (無孔時)N=0											
BRBNM (NBR合成橡膠)																
BRBCM (CR合成橡膠)																
BRBFM (氟素橡膠)																
BRBSM (矽膠A70)																
BRBAM (矽膠A50)																
BUNSE (低彈性橡膠)																

Order 訂購範例: 型式 - A - B - T - F - 選擇螺絲徑No.

Delivery 出貨日: WEB WOS

Price 價格: WEB WOS

型式	Type	A	B	T	NTS基準單價						
					BUTSN	BUTM	BUTL	BUTHN	BRBNM	BRBFM	BRBSM
BUTSN BUTHN BUTM BUTL BRBNM BRBCM BRBFM BRBSM BRBAM BUNSE	25~40	25~40	10	6~10							
				11~15							
				16~20							
				21~25							
				26~30							
	41~60	41~60	10	6~10							
				11~15							
				16~20							
				21~25							
				26~30							
61~80	61~80	10	6~10								
			11~15								
			16~20								
			21~25								
			26~30								
81~100	81~100	10	6~10								
			11~15								
			16~20								
			21~25								
			26~30								
25~40	25~40	15	6~10								
			11~15								
			16~20								
			21~25								
			26~30								
41~60	41~60	15	6~10								
			11~15								
			16~20								
			21~25								
			26~30								
61~80	61~80	15	6~10								
			11~15								
			16~20								
			21~25								
			26~30								
81~100	81~100	15	6~10								
			11~15								
			16~20								
			21~25								
			26~30								

型式	Type	A	B	T	NTS基準單價						
					BUTSN	BUTM	BUTL	BUTHN	BRBNM	BRBFM	BRBSM
BUTSN BUTHN BUTM BUTL BRBNM BRBCM BRBFM BRBSM BRBAM BUNSE	25~40	25~40	10	6~10							
				11~15							
				16~20							
				21~25							
				26~30							
	41~60	41~60	10	6~10							
				11~15							
				16~20							
				21~25							
				26~30							
61~80	61~80	10	6~10								
			11~15								
			16~20								
			21~25								
			26~30								
81~100	81~100	10	6~10								
			11~15								
			16~20								
			21~25								
			26~30								

