

CT-AHLNKC規格變更說明

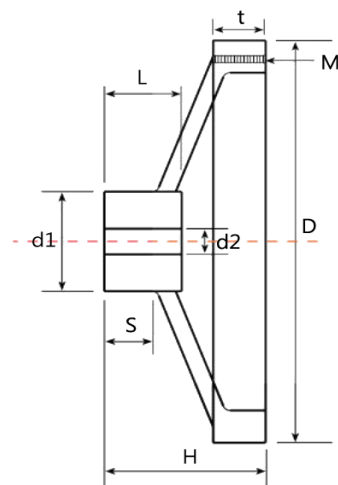

■ 規格變更前

單位：mm

型式		D	H	L	S	d2	d1	M	t	參考質量 (g)
Type	No.									
CT-AHLNKC	75	75	27	17	7	6	26	-	11	300
	100	100	33	19	13.5	8	30	-	13	500
	125	126	43	29	19	8	36	5/16"	15	800
	150	150	52	30	21	8	46	3/8"	20	1300
	160	166	55	30	22	9	45	3/8"	21	1500
	175	177	51	27	18	9	50	3/8"	20	1600
	200	199	54	35	25	9	51	3/8"	21	2200
	230	230	63	38	27	9	60	3/8"	22	2500
	250	250	61	34	21	10	68	3/8"	25	3400
	300	305	66	36	21	10	70	3/8"	26	4500
	350	352	77	38	23	10	76	3/8"	30	6500

■ 規格變更後

單位：mm

型式		D	H	L	S	d2	d1	M	t	參考質量 (g)
Type	No.									
CT-AHLNKC	75	75	26	17	7	7	26	-	11	300
	100	100	33	19	13.5	7	30	-	13.5	500
	125	126	43	29	19	7	36	5/16"	15	800
	150	150	52.5	30	21	8	46	3/8"	20	1300
	160	166	55	30	22	8	45	3/8"	21	1500
	175	177	51	27	18	8	50	3/8"	20	1600
	200	200	54	35	25	8	51	3/8"	21	2200
	230	230	63	38	27	8	60	3/8"	22	2500
	250	250	61	34	21	8	68	3/8"	25	3400
	300	305	66	36	21	10	70	3/8"	26	4500
	350	352	77	38	23	10	76	3/8"	30	6500