

自潤滑滑板

- 銅合金20mm・2/3/4/6螺栓孔型 -

自潤滑滑板

- 銅合金10mm・2/4螺栓孔型 -

-2螺栓孔型- RoHS 10

SEW W=28~75
SEWT W=100~150



-2螺栓孔型-

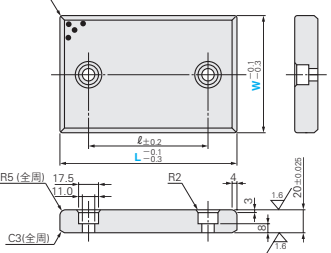

-4螺栓孔型-

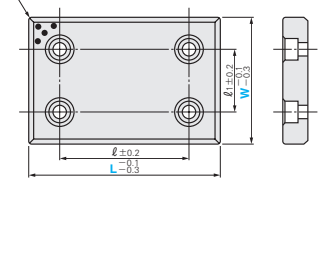

-3螺栓孔型- RoHS 10

SEW W=28~75、L=300



-3螺栓孔型-

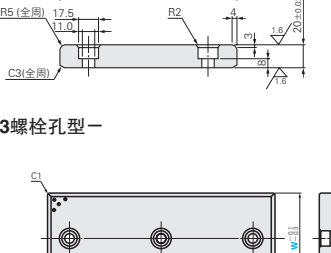

-4螺栓孔型- RoHS 10

SEW W=100~150



-4螺栓孔型-

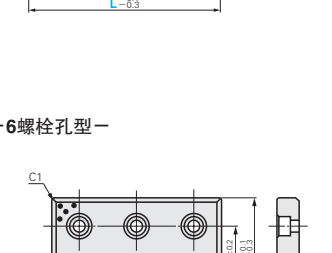

-6螺栓孔型- RoHS 10

SEW W=100~200、L=300、 ϕ =()尺寸

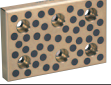

-6螺栓孔型-

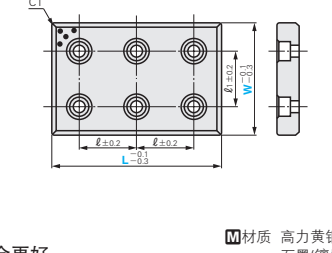

※W=28、38的纵向R为R2。
●滑动方向 W=28、38时仅纵向(L方向)。
●初期使用时涂抹润滑脂，效果会更好。

■材质 高力黄铜 石墨(镶嵌)

ℓ	Catalog No.	W	NO. (L)	孔数
45	SEW	28	75	2
50			100	2
75			*125	2
100			150	2
150			*200	2
200			*250	2
125		*300	3	
45		38	75	2
50			100	2
75			*125	2
100			150	2
150			*200	2
200	*250		2	
125	*300	3		
45	48	75	2	
50		100	2	
75		*125	2	
100		150	2	
150		*200	2	
200		*250	2	
125	*300	3		
45	58	75	2	
50		100	2	
75		*125	2	
100		150	2	
150		*200	2	
200		*250	2	
125	*300	3		
25	75	75	2	
50		100	2	
75		125	2	
100		150	2	
150		*200	2	
200		*250	2	
100	SEWT	100	*300	3
125			*300-H	3
50			100	2
75			125	2
100			150	2
150			200	2
200	*250	2		
200	*300	2		
75	125	125	2	
100		150	2	
150		200	2	
200		*250	2	
200		*300	2	
100		150	150	2
150	200		2	
200	250		2	
200	*300		2	
100	150		2	
150	200		2	
200	250	2		
250	*300	2		

ℓ	ℓ_1	Catalog No.	W	NO. (L)	孔数
50	50	SEW	100	100	4
75				125	4
100				150	4
150				200	4
200				*250	4
200				*300	4
125			*300-H	6	
45			50	75	4
50				100	4
75				150	4
100				200	4
150				*250	4
200	*350	4			
75	75	*125-H	4		
100		*150-H	4		
150		*200-H	4		
200		*250-H	4		
125		*300-H	6		
200		*350-H	4		
45	100	150	4		
50		200	4		
75		250	4		
100		*300	4		
150		*300-H	6		
200		*200	4		
45	150	200	4		
50		250	4		
75		*300	4		
100		*300-H	6		
150		*200	4		
200		*250	4		
250	*300	4			
125	*300-H	6			

Order 订货范围

Catalog No.	W	NO. (L)
SEW	75 -	300
SEWT	150 -	200
SEW	100 -	300-H

Delivery 交货期

- 下述以外
- 库存品
- 隔日上海・广州发货 (P.41) (17:00前订购的库存品可当日发货。)
- 数量≥100时，请另询交货期。
- 带*品 请通过 **MISUMI** 询价。 (<https://www.misumi.com.cn>)

■ 自潤滑滑板用垫片 P.1166

-2螺栓孔型- RoHS 10

STW W=28~75
STWT W=100~150



-2螺栓孔型-

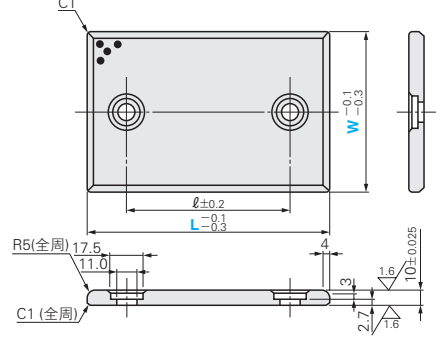

-4螺栓孔型- RoHS 10

STW W=100~150



-4螺栓孔型-

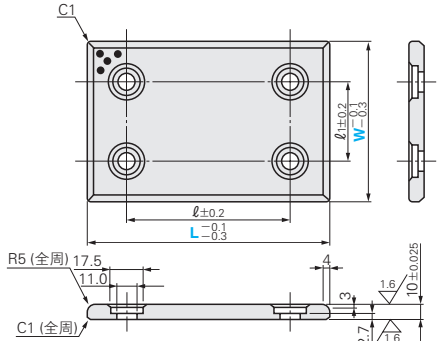

※W=28、38的纵向R为R2。
●滑动方向 W=28、38时仅纵向(L方向)。
●初期使用时涂抹润滑脂，效果会更好。

■材质 高力黄铜 石墨(镶嵌)
■附件 特殊低头螺栓

ℓ	Catalog No.	W	L
45	-2螺栓孔型- STW	28	75
50			100
75			125
100			150
150			200
200			250
45		38	75
50			100
75			125
100			150
150			200
200			250
45	48	75	
50		100	
75		125	
100		150	
150		200	
200		250	
45	58	75	
50		100	
75		*125	
100		150	
150		*200	
200		250	
45	75	75	
50		100	
75		125	
100		150	
150		*175	
200		200	
50	-2螺栓孔型- STWT	100	100
75			125
100			150
150			200
200			250
100			125
150	200		
200	250		
100	150	150	
150		200	
200		250	
100		150	
150		200	
200		250	

ℓ	ℓ_1	Catalog No.	W	L	
50	50	-4螺栓孔型- STW	100	100	
75				125	
100				150	
150				200	
200				250	
100				50	125
150	250				
200	250				
100	100	150	150		
150			200		
200			250		

Order 订货范围

Catalog No.	W	L
STW	75 -	100
STWT	100 -	200

Delivery 交货期

- 下述以外
- 库存品
- 隔日上海・广州发货 (P.41) (17:00前订购的库存品可当日发货。)
- 数量≥100时，请另询交货期。
- 带*品 请通过 **MISUMI** 询价。 (<https://www.misumi.com.cn>)

■ 自潤滑滑板用垫片 P.1166