

自潤滑滑板

- 概要 -

■自潤滑滑板概要

米思米的自潤滑零件是通过将特殊固体润滑剂镶嵌于适当的位置制作而成的。
 烧结合金是在特殊合金中精细均匀分布固体润滑剂，并在毛细孔内浸渗润滑油的合金。
 通过金属母材支撑负载并因镶嵌固体润滑剂，而具有潤滑作用，即使是在恶劣条件下，也显示出优良的自潤滑耐久性。

■特长

- ①最适用于必须经常加润滑油的位置，往复运动或频繁启动与停止的位置，以及难以形成油膜的位置。
- ②可在自潤滑状态下使用，不需要加油装置，可缩短装配工期，减少油品污染公害，美化环境。
- ③耐咬合性能优良。

<注意事项>

- 若对磨材料表面粗糙度过大，可能达不到优良的耐磨损性。
- 初期磨合时涂抹润滑脂，更能发挥优良性能。

■物性

| 材质 | 型号 | 容许负载 N/mm ² | 容许滑动速度 m · min. | 极限PV值 N/mm ² · m/min. | 比重 | 母材硬度 (HB) | 抗拉强度 N/mm ² |
|-------------------------|---|---------------------------|--------------------|-------------------------------------|---------|--------------|---------------------------|
| FC250+石墨 | MWF · MWFT | 5 | 10 | 30 | 7.1~7.3 | <241 | 250 |
| 铜合金+石墨 | SEW · SEWT · STW · STWT · UTW STLW · STS · STCW · STLST · STBW | 50 | 24 | 108 | 8.2 | >210 | 600 |
| 特殊烧结合金 (底板材质: SS400) | SEZ · STZ | 25 | 30 | 98 | - | > 45 | - |

■材质特性及使用区分

| 材质 | 耐磨损性 | 耐咬合性 | 容许负载 | 耐冲击性 | 寿命 | 价格 | 用途 |
|-------------------------|------|------|------|------|----|----|-----------------------------|
| FC250+石墨 | ○ | △ | △ | ○ | ○ | ◎ | 适用于低负载条件。 高负载时容易发生咬合。 |
| 铜合金+石墨 | △ | ◎ | ◎ | ○ | △ | △ | 适用于高负载条件。 普遍使用。 |
| 特殊烧结合金 (底板材质: SS400) | ◎ | ◎ | ◎ | △ | ◎ | ○ | 适用于高负载条件，耐磨损性优异。 耐冲击性稍弱。 |

◎: 优良 ○: 普通 △: 略差

自潤滑滑板

- 鑄铁20mm · 2/3/4/6螺栓孔型 -



—2螺栓孔型— RoHS 10

MWF W= 28~ 75
MWFT W=100~150



—2螺栓孔型—

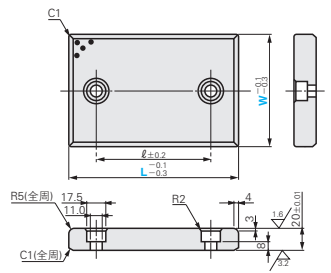

—3螺栓孔型— RoHS 10

MWF W=28~75、L=300



—3螺栓孔型—

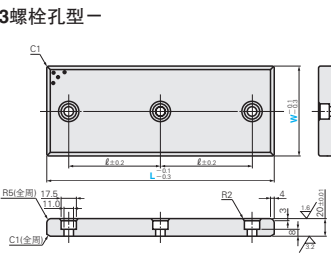

—4螺栓孔型— RoHS 10

MWF W=100~200

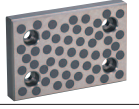

—4螺栓孔型—

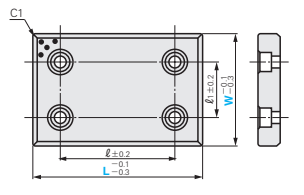

—6螺栓孔型— RoHS 10

MWF W=100~200、
L=300、ℓ=()尺寸

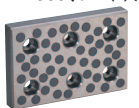

—6螺栓孔型—

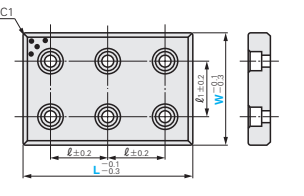

※W=28、38的 ●滑动方向
纵向R为R2。 W=28、38时仅纵向(L方向)。
●初期使用时涂抹润滑脂，效果会更好。

■材质 FC250 石墨(镶嵌)

| ℓ | Catalog No. | W | NO. (L) | 孔数 | ℓ | ℓ1 | Catalog No. | W | NO. (L) | 孔数 | | | | | | |
|-----|-------------|-----|---------|-----|--------|--------|-------------|-----|---------|--------|------|-----|------|------|--------|---|
| 45 | MWF | 28 | 75 | 2 | 50 | 50 | MWF | 100 | 100 | 4 | | | | | | |
| 50 | | | 100 | 2 | | | | | 125 | 4 | | | | | | |
| 75 | | | 125 | 2 | | | | | 150 | 4 | | | | | | |
| 100 | | | 150 | 2 | | | | | 200 | 4 | | | | | | |
| 150 | | | 200 | 2 | | | | | 250 | 4 | | | | | | |
| 200 | | | 250 | 2 | | | | | 300 | 4 | | | | | | |
| 125 | | | 300 | 3 | | | | | *300-H | 6 | | | | | | |
| 45 | | | 38 | 38 | | | | | 75 | 2 | 50 | 50 | 125 | 125 | 4 | |
| 50 | | | | | | | | | 100 | 2 | | | | 150 | 4 | |
| 75 | | | | | | | | | 125 | 2 | | | | 200 | 4 | |
| 100 | | | | | | | | | 150 | 2 | | | | 250 | 4 | |
| 150 | | | | | | | | | 200 | 2 | | | | 300 | 4 | |
| 200 | | 250 | | | 2 | *350 | | 4 | | | | | | | | |
| 125 | | 300 | | | 3 | *125-H | | 4 | | | | | | | | |
| 45 | | 48 | | | 48 | 75 | | 2 | 75 | 75 | | | | 150 | *150-H | 4 |
| 50 | | | | | | 100 | | 2 | | | | | | | *200-H | 4 |
| 75 | | | | | | 125 | | 2 | | | | | | | *250-H | 4 |
| 100 | | | | | | 150 | | 2 | | | | | | | *300-H | 6 |
| 150 | | | | | | 200 | | 2 | | | | | | | *350-H | 4 |
| 200 | | | 250 | 2 | | 150 | | 4 | | | | | | | | |
| 125 | | | 300 | 3 | | 200 | | 4 | | | | | | | | |
| 45 | | | 58 | 58 | | 75 | | 2 | | | 100 | 100 | 150 | | 250 | 4 |
| 50 | | | | | | 100 | | 2 | | | | | | | 300 | 4 |
| 75 | | | | | | 125 | | 2 | | | | | | | *300-H | 6 |
| 100 | 150 | | | | | 2 | 200 | 4 | | | | | | | | |
| 150 | 200 | | | | | 2 | 250 | 4 | | | | | | | | |
| 200 | 250 | 2 | | | 300 | 4 | | | | | | | | | | |
| 125 | 300 | 3 | | | *300-H | 6 | | | | | | | | | | |
| 45 | 75 | 75 | | | 75 | 2 | 150 | 150 | 200 | 150 | | | | 4 | | |
| 50 | | | | | 100 | 2 | | | | 200 | | | | 4 | | |
| 75 | | | | | 125 | 2 | | | | 250 | | | | 4 | | |
| 100 | | | | | 150 | 2 | | | | 300 | | | | 4 | | |
| 150 | | | | | 200 | 2 | | | | *300-H | | | | 6 | | |
| 200 | | | 250 | 2 | 100 | 4 | | | | | | | | | | |
| 125 | | | 300 | 3 | 150 | 4 | | | | | | | | | | |
| 45 | | | 100 | 100 | 75 | 2 | | | | 200 | 200 | 250 | 250 | 4 | | |
| 50 | | | | | 100 | 2 | | | | | | | 300 | 4 | | |
| 75 | | | | | 125 | 2 | | | | | | | *300 | 2 | | |
| 100 | | | | | 150 | 2 | | | | | | | 125 | 2 | | |
| 150 | | | | | 200 | 2 | | | | | | | 150 | 2 | | |
| 200 | 250 | 2 | | | 200 | 2 | | | | | | | | | | |
| 125 | 300 | 3 | | | 250 | 2 | | | | | | | | | | |
| 45 | MWFT | 100 | | | 75 | 2 | 250 | 250 | MWFT | | | | 200 | 200 | 4 | |
| 50 | | | | | 100 | 2 | | | | | | | | 250 | 4 | |
| 75 | | | | | 125 | 2 | | | | | | | | *300 | 2 | |
| 100 | | | | | 150 | 2 | | | | | | | | 125 | 2 | |
| 150 | | | | | 200 | 2 | | | | | | | | 150 | 2 | |
| 200 | | | 250 | 2 | 200 | 2 | | | | | | | | | | |
| 125 | | 300 | 3 | 250 | 2 | | | | | | | | | | | |
| 45 | | 125 | 125 | 75 | 2 | 300 | 300 | 150 | | 200 | 200 | 4 | | | | |
| 50 | | | | 100 | 2 | | | | | | 250 | 4 | | | | |
| 75 | | | | 125 | 2 | | | | | | *300 | 2 | | | | |
| 100 | | | | 150 | 2 | | | | | | 125 | 2 | | | | |
| 150 | | | | 200 | 2 | | | | | | 150 | 2 | | | | |
| 200 | 250 | | | 2 | 200 | | | | 2 | | | | | | | |
| 125 | 300 | 3 | 250 | 2 | | | | | | | | | | | | |
| 45 | 150 | 150 | 75 | 2 | 300 | 300 | 200 | 250 | 250 | 4 | | | | | | |
| 50 | | | 100 | 2 | | | | | 250 | 4 | | | | | | |
| 75 | | | 125 | 2 | | | | | *300 | 2 | | | | | | |
| 100 | | | 150 | 2 | | | | | 125 | 2 | | | | | | |
| 150 | | | 200 | 2 | | | | | 150 | 2 | | | | | | |
| 200 | | | 250 | 2 | | | | | 200 | 2 | | | | | | |
| 125 | 300 | 3 | 250 | 2 | | | | | | | | | | | | |

| | | | |
|------------|-------------|-----|---------|
| Order 订货范例 | Catalog No. | W | NO. (L) |
| | MWF | 75 | 100 |
| | MWFT | 125 | 200 |
| | MWF | 100 | 300-H |

Delivery 交货期

● 下述以外
 库存品
 ① 隔日上海·广州发货 (P.41)
 (17:00前订购的库存品可当日发货。)
 ② 数量≥200时，请另询交货期。

● 带*品
 请通过 **MISUMI** 询价。
<https://www.misumi.com.cn>

■自潤滑滑板用垫片 P.1166