

卸料板导柱

—肩型—

卸料板导柱

—直杆型—



RoHS10

SGPH

RoHS10

SGOH (油槽型)

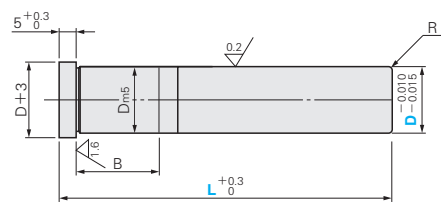
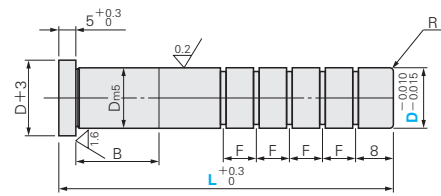
☑ 材质 SUJ2
☑ 硬度 58HRC~

D	槽数(个)							
	40~50	70~80	90~160	180~				
8	2	3	4	5	6	-	-	-
10	2	3	4	5	6	-	-	-
13	2	3	4	5	6	7	8	
16	2	3	4	5	6	7	8	
20	2	3	4	5	6	7	8	
25	2	3	4	5	6	7	8	

※L40~119.5 →F=8
L120~L(C)max.→F=10

☑ 材质 SUJ2 ☑ 硬度 58HRC~

Dm5	R	B	Catalog No.		L										
			Type	D											
8	+0.012 +0.006	1.0	10	SGPH SGOH	8	40	50	60	70	80					
						40	50	60	70	80	90	100			
10	+0.015 +0.007	1.5	13	SGPH SGOH	10	40	50	60	70	80	90	100			
						40	50	60	70	80	90	100	110	120	
13	+0.017 +0.008	2.0	16	SGPH SGOH	13	40	50	60	70	80	90	100	110	120	
						50	60	70	80	90	100	110	120		
16			20	SGPH SGOH	16	60	70	80	90	100	110	120	130	140	
						60	70	80	90	100	110	120	130	140	
20			25	SGPH SGOH	20	70	80	90	100	110	120	130	140		
						70	80	90	100	110	120	130	140		
25			28	SGPH SGOH	25	80	90	100	110	120	130	140			
						80	90	100	110	120	130	140			



Order 订货范例

Catalog No. - L

SGPH 16 - 100



Delivery 交货期

☑ 库存品

☑ 隔日上海·广州发货 P.41
(17:00前订购的库存品可当日发货。)

☑ 数量≥201时, 请另询交货期。



Alterations 追加加工





Catalog No. - L(LC) - (BC·TC·GC·TKC·RC)

SGPH 16 - LC95 - BC15

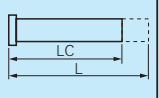
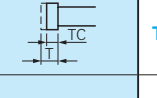

3天发货

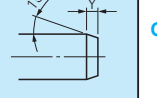
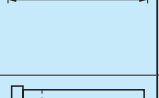
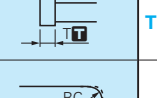
☑ 上海·广州发货
☑ 数量≥101时, 请另询交货期。

Alterations	Code	Spec.	Alterations	Code	Spec.
	LC	变更全长 指定单位0.5mm ●SGPH: 20≤LC<L ●SGOH: 40≤LC<L B尺寸为规格尺寸。 ☑要变更为比L最短规格还短时, 请根据需要并用BC。		TC	变更肩部厚度 指定单位0.1mm 2≤TC<5 ☑全长L缩短(5-TC)。 并用LC时, 全长与LC相同。
	LC	变更全长(长型LC) D LC 指定单位0.5mm 8 80<LC≤120 10 100<LC≤150 13 120<LC≤180 16 140<LC≤200 20 140<LC≤200 25 140<LC≤200		GC	对导柱前端进行锥度加工。 D Y 8 3 10 3 13 5 16 5 20 5 25 5
	BC	变更B尺寸 指定单位1mm 0≤BC≤D×2 ☑全长L为指定尺寸。		TKC	变更肩部厚度公差 T +0.3 → +0.02
				RC	变更前端R D 标准R RC(选择) 8·10 1.0 1.5·2.0 13·16 1.5 2.0·2.5 20·25 2.0 2.5·3.0

☑SGPN与SGON指定追加加工后, 头部无2mm槽。



RoHS10

SGPN

RoHS10

SGON (油槽型)

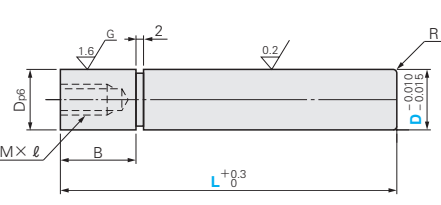
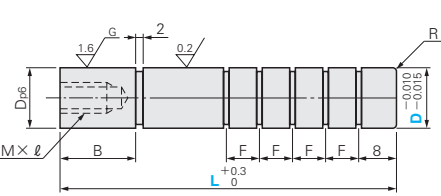
☑ 材质 SUJ2
☑ 硬度 58HRC~

D	槽数(个)							
	40~50	70~80	90~160	180~				
8	2	3	4	5	6	-	-	-
10	2	3	4	5	6	-	-	-
13	2	3	4	5	6	7	8	
16	2	3	4	5	6	7	8	
20	2	3	4	5	6	7	8	
25	2	3	4	5	6	7	8	

※L40~119.5 →F=8
L120~L(C)max.→F=10

☑ 材质 SUJ2 ☑ 硬度 58HRC~

Dp6	M×l 螺距	R	B	Catalog No.		L										
				Type	D											
8	+0.024 +0.015	M5×12 P0.8	1.0	10	SGPN SGON	8	40	50	60	70	80					
							40	50	60	70	80	90	100			
10	+0.029 +0.018	M6×15 P1.0	1.5	13	SGPN SGON	10	40	50	60	70	80	90	100	110	120	
							40	50	60	70	80	90	100	110	120	
13	+0.035 +0.022	M8×20 P1.25	2.0	16	SGPN SGON	13	50	60	70	80	90	100	110	120		
							50	60	70	80	90	100	110	120		
16				20	SGPN SGON	16	60	70	80	90	100	110	120	130	140	
							60	70	80	90	100	110	120	130	140	
20				25	SGPN SGON	20	70	80	90	100	110	120	130	140		
							70	80	90	100	110	120	130	140		
25				28	SGPN SGON	25	80	90	100	110	120	130	140			
							80	90	100	110	120	130	140			



Order 订货范例

Catalog No. - L

SGPN 20 - 80



Delivery 交货期

☑ 库存品

☑ 隔日上海·广州发货 P.41
(17:00前订购的库存品可当日发货。)

☑ 数量≥201时, 请另询交货期。



Alterations 追加加工





Catalog No. - L(LC) - (BC·DKC·GC·RC·TGC)

SGPN 20 - LC75 - BC20

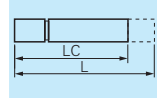
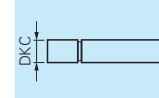

3天发货

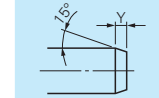
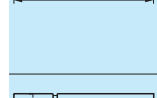
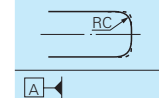
☑ 上海·广州发货
☑ 数量≥101时, 请另询交货期。

Alterations	Code	Spec.	Alterations	Code	Spec.
	LC	变更全长 指定单位0.5mm ●SGPN: 20≤LC<L ●SGON: 40≤LC<L B尺寸为规格尺寸。 ☑要变更为比L最短规格还短时, 请根据需要并用BC。 ☑LC≤25时, 在导柱前端可能开有螺纹底孔。		DKC	变更压入部公差 Dm5 8 +0.012 10 +0.006 13 +0.015 16 +0.007 20 +0.017 25 +0.008
	LC	变更全长(长型LC) D LC 指定单位0.5mm 8 80<LC≤120 10 100<LC≤150 13 120<LC≤180 16 120<LC≤200 20 140<LC≤200 25 140<LC≤200		GC	对导柱前端进行锥度加工。 D Y 8 3 10 3 13 5 16 5 20 5 25 5
	BC	变更B尺寸 指定单位1mm 0≤BC≤D×2 ☑采用BC追加加工时 全长L和螺纹深度为指定尺寸。 ☑BC=0时, 外周无2mm的槽。		RC	变更前端R D 标准R RC(选择) 8·10 1.0 1.5·2.0 13·16 1.5 2.0·2.5 20·25 2.0 2.5·3.0
	TGC	对螺纹端面进行研磨。 垂直度0.01 表面粗糙度1.6a			